



Elektromotoren

MOTORS

Contents

Introduction	3	IE4 motors	23
How to select your Mecaline motor	4	2 pole 50Hz 3000 RPM	23
Product type codes	5	4 pole 50Hz 1500 RPM	24
Nameplate description	6	<u>Dimensions</u>	25
PTC thermistor	6	B3	26
Electrical construction	7	B5-B35	27
		B14-B34	28
<u>Mecaline standard motor selection chart</u>	8	<u>Technical data</u>	29
IE2 2-4-6 pole	8	IEC/EN/UL compatibility	29
IE3 2-pole	9	Mechanical construction	29
IE3 4-pole	11	Electrical construction	31
IE3 6-pole	12	Motors with variable speed drivers	32
IE4 2-pole	13	Winding/insulation/temperature rise classes	33
IE4 4-pole	14	Construction types	34
Motor accessories	15	Bearings	35
		Radial loads	36
		Axial loads	38
TECHNICAL INFORMATION		<u>Additional information</u>	41
<u>Electrical characteristics</u>	18	Spare parts	42
IE2 motors	18	Anti-condensation heater and drain hole	43
2 pole 50Hz 3000 RPM	18	Non drive end shaft extension and canopy	43
4 pole 50Hz 1500 RPM	18	Brake, hand release, separately driven fan encoder and backstop	44
6 pole 50Hz 1000 RPM	19		
IE3 motors	20		
2 pole 50Hz 3000 RPM	20		
4 pole 50Hz 1500 RPM	21		
6 pole 50Hz 1000 RPM	22		

Introduction

We now offer quality three-phase asynchronous motors in both aluminium and cast-iron.

Our motors are designed to be suitable for the most common applications. Mecaline motors deliver benefits such as excellent heat dissipation to reduce temperatures on windings and bearings. With IE3 and IE4 efficiency they provide significantly lower overall energy consumption to reduce the total cost of ownership and extend product life.

Every motor comes with a 2-year warranty and is designed to the highest product specification, including:

- Totally enclosed fan cooled IC411
- Premium bearings
- Insulation Class F
- Motors finished in RAL 7031 paint
- S1 duty
- IP55 rating
- Multi-mount design with removable feet providing mounting flexibility up to 280 frame
- Standard supply voltage 230/400V up to 3kW and 400/690V beyond

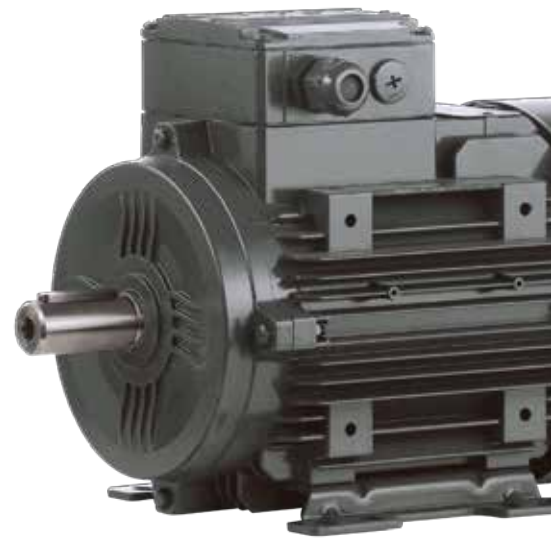

All of our motors, which have that UL logo on nameplate are approved by UL and manufactured according to UL 1004-1 and CSA C22.2.

Aluminium motors

Mecaline's aluminium motors are available in the following specifications:

- 0.75kW - 11kW
- 2, 4 or 6 pole
- B3, B5 as standard, B14 as standard up to size 160, B34 and B35 options are also available
- PTC thermistors on 132 frame and above as standard

Cast iron motors

Mecaline's cast iron motors are available in the following specifications:

- 18.5kW and above
- 2, 4 or 6 pole
- B3, B5 as standard, B14 as standard up to size 160, B34 and B35 options are also available
- PTC thermistors on 132 frame and above as standard

How to select your Mecaline motor

An electric motor is defined by:

- Output power rating (kW)
- Number of poles (rotation speed in RPM)
- Frame size (distance in mm between the centre of the shaft and the base of the motor)
- Mounting (B3=Foot, B5=Flange, B14=Face, B34=Foot/face, B35=Foot/flange)
- Efficiency class
- Material (A=Aluminium / CI=Cast iron)

Use the tables to select:

- Correct output rating (kW),
- Number of poles and Frame size
- Choose the applicable foot/flange mounting
- Consider the motor material (appropriate)
- The Rubix Engineering code refers to your selection

An electric motor converts electrical energy into mechanical energy. The most common and simple industrial motor is the three-phase asynchronous AC motor.

Common definitions:

Asynchronous = Can also be referred to as "squirrel cage" or "induction" motor

AC = Alternating Current (typically produced by generators or alternators)

IEC = European standardised ratings / performance/ dimensional characteristics (IEC standards define standard motor output vs frame size ratios and main critical dimensions)

**Note - motor length, terminal box dimensions/position are not covered by these standards*

Poles = The synchronous speed of an electric motor is determined by multiplying the cycles per second by 60 (1 minute) divided by the number of pairs of poles

For example, a 2 pole motor's speed is determined as follows:

- Speed (RPM) = 50 (cycles/second) x 60(seconds)(=3,000 RPM)
- 1 (pair of poles)

If the motor has 4 poles the speed will be 1500 RPM (2 pairs of poles) etc.

Product

Type codes

3 EL 132 S 4 C FC B0 C34

3



Motor efficiency classes

2: IE2
3: IE3
4: IE4

EL



Basic motor type

EL: Aluminium housing standard motors
EG: Cast iron housing standard motors

132



Frame size: 63, 71, 80, 90, 100, 112, 132, 160, 180, 200, 225, 250, 280
Height of the shaft axis from feet base of motor (mm)

S



Housing length

S: Short
M: Medium
L: Long

4



Number of poles

2: 2 poles 3000 RPM
4: 4 poles 1500 RPM
6: 6 poles 1000 RPM

C



Core length: A, B, C, D, E, F, G

FC



Construction types/ flange types

PD: B3 foot mounted
FA: B5 flange
FC: B14 flange
FS: Special flange
PA: B35
PC: B34

B0



Electrical specifications

AA...ZZ Voltage, Frequency and electrical features

1st digit: Voltage and frequency
A: 230/400V 50Hz
B: 400/690V 50Hz

0 = No PTC
A = PTC included

C34



Additional motor features:

C34: standard motor

Nameplate description

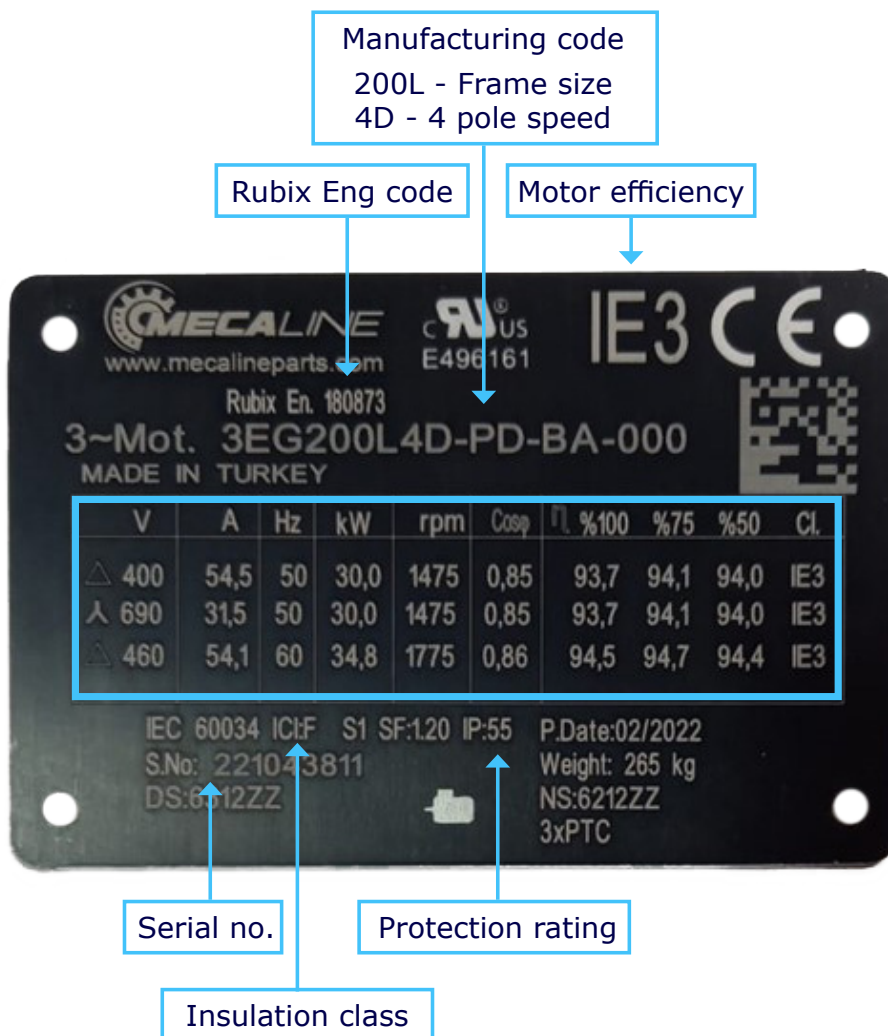

V: Voltage

A: Amps

kW: Power kilo watt

RPM: Speed

PTC thermistor

PTC thermistor

If the motor is exposed to excessive load, the internal resistance of the thermistor attached to the motor windings increases due to the heating of the motor windings and opens the circuit when the insulation class limit value is reached. This prevents the winding from being damaged by cutting off the current in the windings. Only can be used with an electronic circuit.

PTC is standard on Mecaline motors from frame size 132.

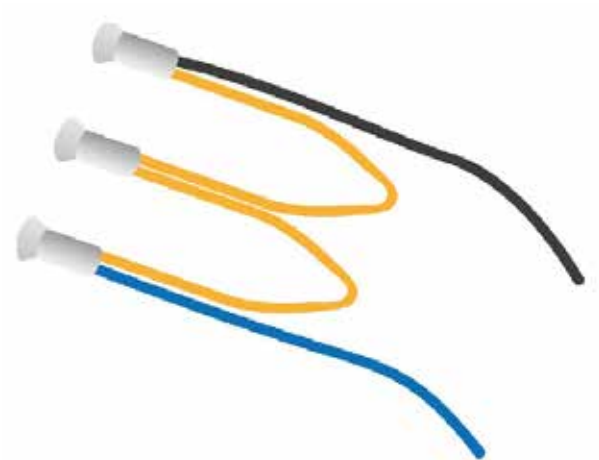

Electrical construction

Standard Mecaline motors have insulation Class F while the temperature rise is Class B. This means the motors will have a longer service life and work under hard conditions.

Electrical connections

Cable gland and blind cap														
Frame size	063	071	080	090	100	112	132	160	180	200	225	250	280	
Cable glands	M16x1,5	M20x1,5			M25x1,5			2 x M32x1,5		2 x M40x1,5		2 x M50x1,5		2 x M63x1,5
Blind cap	M16x1,5				M25x1,5			-		-		-		-

Terminal connections														
Frame size	063	071	080	090	100	112	132	160	180	200	225	250	280	
Terminal size	M4				M5			M6			M8		M10	

The motors shall be connected in star or delta according to rated voltage given in their nameplate and the network voltage that they will be connected. For phase to phase 400V supply the motors with 230/400V nameplate values shall be connected in star and the motors with 400/690V nameplates values shall be connected in delta.

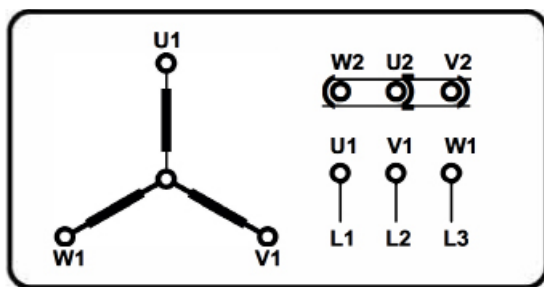

Y Star Connection

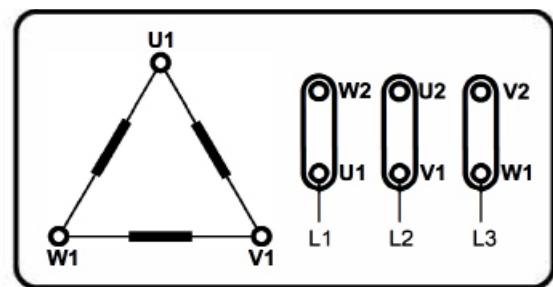

Δ Delta Connection

Motors at 60Hz network

Standard Mecaline motors that have been manufactured for 50 Hz power supply can be used at 60Hz network. The ratios given below indicate changes in the given rated values.

50 Hz rated voltage	60 Hz rated voltage	Rated speed	Rated power	Rated torque	Rated current	Starting torque	Break down torque	Starting current
230V	220V	1.193	1	0.84	0.97	0.77	0.8	0.8
400V	380V	1.193	1	0.84	0.97	0.77	0.8	0.8
400V	440V	1.20	1.16	0.97	0.98	0.87	0.9	0.9

IE2 efficiency level

230/400V-3ph-50Hz IP55

2 Pole / 3000 RPM	Rubix Engineering code	kW	Speed	Pole	Frame size	Mounting	Motor reference	Material	Weight motor (kg)
	891423	0.18	3000	2	63	B3	2EL063M2A-PD-AO-C34	ALU	4.32
	891468	0.18	3000	2	63	B5	2EL063M2A-FA-AO-C34	ALU	4.32
	891513	0.18	3000	2	63	B14	2EL063M2A-FC-AO-C34	ALU	4.32
	891424	0.25	3000	2	63	B3	2EL063M2B-PD-AO-C34	ALU	4.84
	891469	0.25	3000	2	63	B5	2EL063M2B-FA-AO-C34	ALU	4.84
	891514	0.25	3000	2	63	B14	2EL063M2B-FC-AO-C34	ALU	4.84
	891425	0.37	3000	2	71	B3	2EL071M2A-PD-AO-C34	ALU	6.32
	891470	0.37	3000	2	71	B5	2EL071M2A-FA-AO-C34	ALU	6.32
	891515	0.37	3000	2	71	B14	2EL071M2A-FC-AO-C34	ALU	6.32
	891426	0.55	3000	2	71	B3	2EL071M2B-PD-AO-C34	ALU	7.3
	891471	0.55	3000	2	71	B5	2EL071M2B-FA-AO-C34	ALU	7.3
891516	0.55	3000	2	71	B14	2EL071M2B-FC-AO-C34	ALU	7.3	

4 Pole / 1500 RPM	Rubix Engineering code	kW	Speed	Pole	Frame size	Mounting	Motor reference	Material	Weight motor (kg)
	891437	0.12	1500	4	63	B3	2EL063M4B-PD-AO-C34	ALU	4.14
	891482	0.12	1500	4	63	B5	2EL063M4B-FA-AO-C34	ALU	4.14
	891527	0.12	1500	4	63	B14	2EL063M4B-FC-AO-C34	ALU	4.14
	891438	0.18	1500	4	63	B3	2EL063M4C-PD-AO-C34	ALU	4.71
	891483	0.18	1500	4	63	B5	2EL063M4C-FA-AO-C34	ALU	4.71
	891528	0.18	1500	4	63	B14	2EL063M4C-FC-AO-C34	ALU	4.71
	891439	0.25	1500	4	71	B3	2EL071M4B-PD-AO-C34	ALU	6.05
	891484	0.25	1500	4	71	B5	2EL071M4B-FA-AO-C34	ALU	6.05
	891529	0.25	1500	4	71	B14	2EL071M4B-FC-AO-C34	ALU	6.05
	891440	0.37	1500	4	71	B3	2EL071M4C-PD-AO-C34	ALU	6.95
	891485	0.37	1500	4	71	B5	2EL071M4C-FA-AO-C34	ALU	6.95
	891530	0.37	1500	4	71	B14	2EL071M4C-FC-AO-C34	ALU	6.95
	891441	0.55	1500	4	80	B3	2EL080M4B-PD-AO-C34	ALU	9.29
	891486	0.55	1500	4	80	B5	2EL080M4B-FA-AO-C34	ALU	9.29
891531	0.55	1500	4	80	B14	2EL080M4B-FC-AO-C34	ALU	9.29	

6 Pole / 1000 RPM	Rubix Engineering code	kW	Speed	Pole	Frame size	Mounting	Motor reference	Material	Weight motor (kg)
	891558	0.18	1000	6	71	B3	2EL071M6B-PD-AO-C34	ALU	5.82
	891566	0.18	1000	6	71	B5	2EL071M6B-FA-AO-C34	ALU	5.82
	891562	0.18	1000	6	71	B14	2EL071M6B-FC-AO-C34	ALU	5.82
	891559	0.25	1000	6	71	B3	2EL071M6C-PD-AO-C34	ALU	6.55
	891567	0.25	1000	6	71	B5	2EL071M6C-FA-AO-C34	ALU	6.55
	891563	0.25	1000	6	71	B14	2EL071M6C-FC-AO-C34	ALU	6.55
	891560	0.37	1000	6	80	B3	2EL080M6A-PD-AO-C34	ALU	8.54
	891568	0.37	1000	6	80	B5	2EL080M6A-FA-AO-C34	ALU	8.54
	891564	0.37	1000	6	80	B14	2EL080M6A-FC-AO-C34	ALU	8.54
	891561	0.55	1000	6	80	B3	2EL080M6B-PD-AO-C34	ALU	9.92
	891569	0.55	1000	6	80	B5	2EL080M6B-FA-AO-C34	ALU	9.92
891565	0.55	1000	6	80	B14	2EL080M6B-FC-AO-C34	ALU	9.92	

IE3 efficiency level

230/400V-3ph-50Hz IP55

2 Pole / 3000 RPM	Rubix Engineering code	kW	Speed	Pole	Frame size	Mounting	Motor reference	Material	Weight motor (kg)
	891427	0.75	3000	2	80	B3	3EL080M2B-PD-A0-C34	ALU	10.34
	891472	0.75	3000	2	80	B5	3EL080M2B-FA-A0-C34	ALU	10.34
	891517	0.75	3000	2	80	B14	3EL080M2B-FC-A0-C34	ALU	10.34
	891428	1.1	3000	2	80	B3	3EL080M2C-PD-A0-C34	ALU	11.95
	891473	1.1	3000	2	80	B5	3EL080M2C-FA-A0-C34	ALU	11.95
	891518	1.1	3000	2	80	B14	3EL080M2C-FC-A0-C34	ALU	11.95
	891429	1.5	3000	2	90	B3	3EL090S2B-PD-A0-C34	ALU	15.44
	891474	1.5	3000	2	90	B5	3EL090S2B-FA-A0-C34	ALU	15.44
	891519	1.5	3000	2	90	B14	3EL090S2B-FC-A0-C34	ALU	15.44
	891430	2.2	3000	2	90	B3	3EL090L2C-PD-A0-C34	ALU	18.72
	891475	2.2	3000	2	90	B5	3EL090L2C-FA-A0-C34	ALU	18.72
	891520	2.2	3000	2	90	B14	3EL090L2C-FC-A0-C34	ALU	18.72
	891431	3	3000	2	100	B3	3EL100L2C-PD-A0-C34	ALU	24.8
	891476	3	3000	2	100	B5	3EL100L2C-FA-A0-C34	ALU	24.8
	891521	3	3000	2	100	B14	3EL100L2C-FC-A0-C34	ALU	24.8

400/690V-3ph-50Hz IP55

2 Pole / 3000 RPM	Rubix Engineering code	kW	Speed	Pole	Frame size	Mounting	Motor reference	Material	Weight motor (kg)
	891432	4	3000	2	112	B3	3EL112M2C-PD-BO-C34	ALU	32.37
	891477	4	3000	2	112	B5	3EL112M2C-FA-BO-C34	ALU	32.37
	891522	4	3000	2	112	B14	3EL112M2C-FC-BO-C34	ALU	32.37
	891433	5.5	3000	2	132	B3	3EL132S2B-PD-BA-C34	ALU	45.91
	891478	5.5	3000	2	132	B5	3EL132S2B-FA-BA-C34	ALU	45.91
	891523	5.5	3000	2	132	B14	3EL132S2B-FC-BA-C34	ALU	45.91
	891434	7.5	3000	2	132	B3	3EL132S2C-PD-BA-C34	ALU	52.25
	891479	7.5	3000	2	132	B5	3EL132S2C-FA-BA-C34	ALU	52.25
	891524	7.5	3000	2	132	B14	3EL132S2C-FC-BA-C34	ALU	52.25
	891435	11	3000	2	160	B3	3EL160M2B-PD-BA-C34	ALU	83.3
	891480	11	3000	2	160	B5	3EL160M2B-FA-BA-C34	ALU	83.3
	891525	11	3000	2	160	B14	3EL160M2B-FC-BA-C34	ALU	83.3
	891436	15	3000	2	160	B3	3EL160M2C-PD-BA-C34	ALU	94.91
	891481	15	3000	2	160	B5	3EL160M2C-FA-BA-C34	ALU	94.91
	891526	15	3000	2	160	B14	3EL160M2C-FC-BA-C34	ALU	94.91
	891452	18.5	3000	2	160	B3	3EL160L2D-PD-BA-C34	ALU	104.57
	891497	18.5	3000	2	160	B5	3EL160L2D-FA-BA-C34	ALU	104.57
	891453	22	3000	2	180	B3	3EG180M2B-PD-BA-C34	CI	173.14
	891498	22	3000	2	180	B5	3EG180M2B-FA-BA-C34	CI	173.14
891454	30	3000	2	200	B3	3EG200L2B-PD-BA-C34	CI	237.92	
891499	30	3000	2	200	B5	3EG200L2B-FA-BA-C34	CI	237.92	
891455	37	3000	2	200	B3	3EG200L2C-PD-BA-C34	CI	261.68	

Technical pages from page 17

* All items marked ALU come with removable feet as standard

IE3 efficiency level

400/690V-3ph-50Hz IP55

	Rubix Engineering code	kW	Speed	Pole	Frame size	Mounting	Motor reference	Material	Weight motor (kg)
2 Pole / 3000 RPM	891500	37	3000	2	200	B5	3EG200L2C-FA-BA-C34	CI	261.68
	891456	45	3000	2	225	B3	3EG225M2C-PD-BA-C34	CI	335.68
	891501	45	3000	2	225	B5	3EG225M2C-FA-BA-C34	CI	335.68
	891457	55	3000	2	250	B3	3EG250M2C-PD-BA-C34	CI	432.88
	891502	55	3000	2	250	B5	3EG250M2C-FA-BA-C34	CI	432.88
	891458	75	3000	2	280	B3	3EG280S2B-PD-BA-C34	CI	565.29
	891503	75	3000	2	280	B5	3EG280S2B-FA-BA-C34	CI	565.29
	891459	90	3000	2	280	B3	3EG280M2C-PD-BA-C34	CI	629.04
	891504	90	3000	2	280	B5	3EG280M2C-FA-BA-C34	CI	629.04

Technical pages from page 17

* All items marked ALU come with removable feet as standard

IE3 efficiency level

230/400V-3ph-50Hz IP55

4 Pole / 1500 RPM	Rubix Engineering code	kW	Speed	Pole	Frame size	Mounting	Motor reference	Material	Weight motor (kg)
	891442	0.75	1500	4	80	B3	3EL080M4D-PD-AO-C34	ALU	11.15
	891487	0.75	1500	4	80	B5	3EL080M4D-FA-AO-C34	ALU	11.15
	891443	1.1	1500	4	90	B3	3EL090S4C-PD-AO-C34	ALU	15.05
	891488	1.1	1500	4	90	B5	3EL090S4C-FA-AO-C34	ALU	15.05
	891533	1.1	1500	4	90	B14	3EL090S4C-FC-AO-C34	ALU	15.05
	891444	1.5	1500	4	90	B3	3EL090L4D-PD-AO-C34	ALU	17.43
	891489	1.5	1500	4	90	B5	3EL090L4D-FA-AO-C34	ALU	17.43
	891534	1.5	1500	4	90	B14	3EL090L4D-FC-AO-C34	ALU	17.43
	891445	2.2	1500	4	100	B3	3EL100L4C-PD-AO-C34	ALU	23.73
	891490	2.2	1500	4	100	B5	3EL100L4C-FA-AO-C34	ALU	23.73
	891535	2.2	1500	4	100	B14	3EL100L4C-FC-AO-C34	ALU	23.73
	891446	3	1500	4	100	B3	3EL100L4D-PD-AO-C34	ALU	26.36
	891491	3	1500	4	100	B5	3EL100L4D-FA-AO-C34	ALU	26.36
	891536	3	1500	4	100	B14	3EL100L4D-FC-AO-C34	ALU	26.36

400/690V-3ph-50Hz IP55

4 Pole / 1500 RPM	Rubix Engineering code	kW	Speed	Pole	Frame size	Mounting	Motor reference	Material	Weight motor (kg)
	891447	4	1500	4	112	B3	3EL112M4D-PD-BO-C34	ALU	34.41
	891492	4	1500	4	112	B5	3EL112M4D-FA-BO-C34	ALU	34.41
	891448	5.5	1500	4	132	B3	3EL132S4C-PD-BO-C34	ALU	49.93
	891493	5.5	1500	4	132	B5	3EL132S4C-FA-BA-C34	ALU	49.93
	891538	5.5	1500	4	132	B14	3EL132S4C-FC-BA-C34	ALU	49.93
	891449	7.5	1500	4	132	B3	3EL132M4D-PD-BA-C34	ALU	56.78
	891494	7.5	1500	4	132	B5	3EL132M4D-FA-BA-C34	ALU	56.78
	891539	7.5	1500	4	132	B14	3EL132M4D-FC-BA-C34	ALU	56.78
	891450	11	1500	4	160	B3	3EL160M4C-PD-BA-C34	ALU	90.67
	891495	11	1500	4	160	B5	3EL160M4C-FA-BA-C34	ALU	90.67
	891540	11	1500	4	160	B14	3EL160M4C-FC-BA-C34	ALU	90.67
	891451	15	1500	4	160	B3	3EL160L4E-PD-BA-C34	ALU	103.25
	891496	15	1500	4	160	B5	3EL160L4E-FA-BA-C34	ALU	103.25
	891541	15	1500	4	160	B14	3EL160L4E-FC-BA-C34	ALU	103.25
	891460	18.5	1500	4	180	B3	3EG180M4C-PD-BA-C34	CI	177.13
	891505	18.5	1500	4	180	B5	3EG180M4C-FA-BA-C34	CI	177.13
	891461	22	1500	4	180	B3	3EG180L4D-PD-BA-C34	CI	192.68
	891506	22	1500	4	180	B5	3EG180L4D-FA-BA-C34	CI	192.68
	891462	30	1500	4	200	B3	3EG200L4D-PD-BA-C34	CI	258.36
	891507	30	1500	4	200	B5	3EG200L4D-FA-BA-C34	CI	258.36
	891463	37	1500	4	225	B3	3EG225S4C-PD-BA-C34	CI	327.02
	891508	37	1500	4	225	B5	3EG225S4C-FA-BA-C34	CI	327.02
	891464	45	1500	4	225	B3	3EG225M4D-PD-BA-C34	CI	357.51
	891509	45	1500	4	225	B5	3EG225M4D-FA-BA-C34	CI	357.51
	891465	55	1500	4	250	B3	3EG250M4D-PD-BA-C34	CI	461.05
	891510	55	1500	4	250	B5	3EG250M4D-FA-BA-C34	CI	461.05
	891466	75	1500	4	280	B3	3EG280S4C-PD-BA-C34	CI	615.77
	891511	75	1500	4	280	B5	3EG280S4C-FA-BA-C34	CI	615.77
	891467	90	1500	4	280	B3	3EG280M4D-PD-BA-C34	CI	670
891512	90	1500	4	280	B5	3EG280M4D-FA-BA-C34	CI	670	

IE3 efficiency level

230/400V-3ph-50Hz IP55

6 Pole / 1000 RPM	Rubix Engineering code	kW	Speed	Pole	Frame size	Mounting	Motor reference	Material	Weight motor (kg)
	891570	0.75	1000	6	90	B3	3EL090S6B-PD-AO-C34	ALU	13.9
	891588	0.75	1000	6	90	B5	3EL090S6B-FA-AO-C34	ALU	13.9
	891571	1.1	1000	6	90	B3	3EL090L6C-PD-AO-C34	ALU	16.84
	891589	1.1	1000	6	90	B5	3EL090L6C-FA-AO-C34	ALU	16.84
	891580	1.1	1000	6	90	B14	3EL090L6C-FC-AO-C34	ALU	16.84
	891572	1.5	1000	6	100	B3	3EL100L6B-PD-AO-C34	ALU	21.86
	891590	1.5	1000	6	100	B5	3EL100L6B-FA-AO-C34	ALU	21.86
	891581	1.5	1000	6	100	B14	3EL100L6B-FC-AO-C34	ALU	21.86
	891573	2.2	1000	6	112	B3	3EL112M6B-PD-AO-C34	ALU	29.46
	891591	2.2	1000	6	112	B5	3EL112M6B-FA-AO-C34	ALU	29.46
	891582	2.2	1000	6	112	B14	3EL112M6B-FC-AO-C34	ALU	29.46

400/690V-3ph-50Hz IP55

6 Pole / 1000 RPM	Rubix Engineering code	kW	Speed	Pole	Frame size	Mounting	Motor reference	Material	Weight motor (kg)
	891574	3	1000	6	132	B3	3EL132S6B-PD-BA-C34	ALU	42.43
	891592	3	1000	6	132	B5	3EL132S6B-FA-BA-C34	ALU	42.43
	891575	4	1000	6	132	B3	3EL132M6C-PD-BA-C34	ALU	48.91
	891593	4	1000	6	132	B5	3EL132M6C-FA-BA-C34	ALU	48.91
	891584	4	1000	6	132	B14	3EL132M6C-FC-BA-C34	ALU	48.91
	891576	5.5	1000	6	132	B3	3EL132M6D-PD-BA-C34	ALU	54.62
	891594	5.5	1000	6	132	B5	3EL132M6D-FA-BA-C34	ALU	54.62
	891585	5.5	1000	6	132	B14	3EL132M6D-FC-BA-C34	ALU	54.62
	891577	7.5	1000	6	160	B3	3EL160M6D-PD-BA-C34	ALU	84.7
	891595	7.5	1000	6	160	B5	3EL160M6D-FA-BA-C34	ALU	84.7
	891586	7.5	1000	6	160	B14	3EL160M6D-FC-BA-C34	ALU	84.7
	891578	11	1000	6	160	B3	3EL160L6E-PD-BA-C34	ALU	99.29
	891596	11	1000	6	160	B5	3EL160L6E-FA-BA-C34	ALU	99.29
	891587	11	1000	6	160	B14	3EL160L6E-FC-BA-C34	ALU	99.29
	891597	18.5	1000	6	200	B3	3EG200L6C-PD-BA-C34	CI	234.03
	891603	18.5	1000	6	200	B5	3EG200L6C-FA-BA-C34	CI	234.03
	891598	22	1000	6	200	B3	3EG200L6D-PD-BA-C34	CI	248.39
	891604	22	1000	6	200	B5	3EG200L6D-FA-BA-C34	CI	248.39
	891599	30	1000	6	225	B3	3EG225S6C-PD-BA-C34	CI	326.01
	891605	30	1000	6	225	B5	3EG225S6C-FA-BA-C34	CI	326.01
	891600	37	1000	6	250	B3	3EG250M6C-PD-BA-C34	CI	430.89
	891606	37	1000	6	250	B5	3EG250M6C-FA-BA-C34	CI	430.89
	891602	55	1000	6	280	B3	3EG280M6C-PD-BA-C34	CI	604.76
891608	55	1000	6	280	B5	3EG280M6C-FA-BA-C34	CI	604.76	

Technical pages from page 17

* All items marked ALU come with removable feet as standard

IE4 efficiency level

400/690v-3ph-50Hz IP55

2 Pole / 3000 RPM	Rubix Engineering code	kW	Speed	Pole	Frame size	Mounting	Motor reference	Material	Weight motor (kg)
	894221	4	3000	2	112	B14	4EL112M2D-FC-B0-C34	ALU	34.41
	894222	4	3000	2	112	B3	4EL112M2D-PD-B0-C34	ALU	34.41
	894220	4	3000	2	112	B5	4EL112M2D-FA-B0-C34	ALU	34.90
	894225	5.5	3000	2	132	B14	4EL132S2C-FC-BA-C34	ALU	45.91
	894226	5.5	3000	2	132	B3	4EL132S2C-PD-BA-C34	ALU	45.91
	894224	5.5	3000	2	132	B5	4EL132S2C-FA-BA-C34	ALU	45.91
	894235	7.5	3000	2	132	B14	4EL132S2D-FC-BA-C34	ALU	52.25
	894236	7.5	3000	2	132	B3	4EL132S2D-PD-BA-C34	ALU	52.25
	894234	7.5	3000	2	132	B5	4EL132S2D-FA-BA-C34	ALU	52.25
	894239	11	3000	2	160	B14	4EG160M2C-FC-BA-C34	CI	133.00
	894245	11	3000	2	160	B14	4EL160M2C-FC-BA-C34	ALU	83.30
	894240	11	3000	2	160	B3	4EG160M2C-PD-BA-C34	CI	133.00
	894246	11	3000	2	160	B3	4EL160M2C-PD-BA-C34	ALU	83.30
	894238	11	3000	2	160	B5	4EG160M2C-FA-BA-C34	CI	133.00
	894244	11	3000	2	160	B5	4EL160M2C-FA-BA-C34	ALU	83.30
	894255	15	3000	2	160	B14	4EG160M2D-FC-BA-C34	CI	135.00
	894261	15	3000	2	160	B14	4EL160M2D-FC-BA-C34	ALU	94.91
	894256	15	3000	2	160	B3	4EG160M2D-PD-BA-C34	CI	135.00
	894262	15	3000	2	160	B3	4EL160M2D-PD-BA-C34	ALU	94.91
894254	15	3000	2	160	B5	4EG160M2D-FA-BA-C34	CI	135.00	
894260	15	3000	2	160	B5	4EL160M2D-FA-BA-C34	ALU	94.91	
894265	18.5	3000	2	160	B14	4EG160L2E-FC-BA-C34	CI	145.00	
894271	18.5	3000	2	160	B14	4EL160L2E-FC-BA-C34	ALU	104.57	
894266	18.5	3000	2	160	B3	4EG160L2E-PD-BA-C34	CI	145.00	
894272	18.5	3000	2	160	B3	4EL160L2E-PD-BA-C34	ALU	104.57	
894264	18.5	3000	2	160	B5	4EG160L2E-FA-BA-C34	CI	145.00	
894270	18.5	3000	2	160	B5	4EL160L2E-FA-BA-C34	ALU	104.57	
894282	22	3000	2	180	B3	4EG180M2C-PD-BA-C34	CI	173.14	
894288	22	3000	2	180	B3	4EL180M2C-PD-BA-C34	ALU	133.00	
894280	22	3000	2	180	B5	4EG180M2C-FA-BA-C34	CI	173.14	
894286	22	3000	2	180	B5	4EL180M2C-FA-BA-C34	ALU	195.00	
894292	30	3000	2	200	B3	4EG200L2C-PD-BA-C34	CI	237.92	
894290	30	3000	2	200	B5	4EG200L2C-FA-BA-C34	CI	237.92	
894299	37	3000	2	200	B3	4EG200L2D-PD-BA-C34	CI	261.68	
894297	37	3000	2	200	B5	4EG200L2D-FA-BA-C34	CI	551.55	
894306	45	3000	2	225	B3	4EG225M2D-PD-BA-C34	CI	335.68	
894304	45	3000	2	225	B5	4EG225M2D-FA-BA-C34	CI	335.68	
894313	55	3000	2	250	B3	4EG250M2D-PD-BA-C34	CI	432.88	
894311	55	3000	2	250	B5	4EG250M2D-FA-BA-C34	CI	432.88	
894320	75	3000	2	280	B3	4EG280S2C-PD-BA-C34	CI	565.29	
894318	75	3000	2	280	B5	4EG280S2C-FA-BA-C34	CI	565.29	
894327	90	3000	2	280	B3	4EG280M2D-PD-BA-C34	CI	629.04	
894325	90	3000	2	280	B5	4EG280M2D-FA-BA-C34	CI	629.04	

IE4 efficiency level

400/690v-3ph-50Hz IP55

	Rubix Engineering code	kW	Speed	Pole	Frame size	Mounting	Motor reference	Material	Weight motor (kg)
4 Pole / 1500 RPM	894228	5.5	1500	4	132	B14	4EL132S4D-FC-BA-C34	ALU	49.93
	894229	5.5	1500	4	132	B3	4EL132S4D-PD-BA-C34	ALU	49.93
	894227	5.5	1500	4	132	B5	4EL132S4D-FA-BA-C34	ALU	49.93
	894232	7.5	1500	4	132	B14	4EL132M4F-FC-BA-C34	ALU	56.78
	894233	7.5	1500	4	132	B3	4EL132M4F-PD-BA-C34	ALU	56.78
	894231	7.5	1500	4	132	B5	4EL132M4F-FA-BA-C34	ALU	56.78
	894242	11	1500	4	160	B14	4EG160M4E-FC-BA-C34	CI	137.00
	894248	11	1500	4	160	B14	4EL160M4E-FC-BA-C34	ALU	90.67
	894243	11	1500	4	160	B3	4EG160M4E-PD-BA-C34	CI	137.00
	894249	11	1500	4	160	B3	4EL160M4E-PD-BA-C34	ALU	90.67
	894241	11	1500	4	160	B5	4EG160M4E-FA-BA-C34	CI	137.00
	894247	11	1500	4	160	B5	4EL160M4E-FA-BA-C34	ALU	90.67
	894252	15	1500	4	160	B14	4EG160L4F-FC-BA-C34	CI	152.00
	894258	15	1500	4	160	B14	4EL160L4F-FC-BA-C34	ALU	103.25
	894253	15	1500	4	160	B3	4EG160L4F-PD-BA-C34	CI	152.00
	894259	15	1500	4	160	B3	4EL160L4F-PD-BA-C34	ALU	103.25
	894251	15	1500	4	160	B5	4EG160L4F-FA-BA-C34	CI	152.00
	894257	15	1500	4	160	B5	4EL160L4F-FA-BA-C34	ALU	103.25
	894268	18.5	1500	4	180	B14	4EG180M4D-FC-BA-C34	CI	190.00
	894269	18.5	1500	4	180	B3	4EG180M4D-PD-BA-C34	CI	177.13
	894275	18.5	1500	4	180	B3	4EL180M4D-PD-BA-C34	ALU	190.00
	894267	18.5	1500	4	180	B5	4EG180M4D-FA-BA-C34	CI	177.13
	894273	18.5	1500	4	180	B5	4EL180M4D-FA-BA-C34	ALU	190.00
	894279	22	1500	4	180	B3	4EG180L4E-PD-BA-C34	CI	192.68
	894285	22	1500	4	180	B3	4EL180L4E-PD-BA-C34	ALU	212.00
	894277	22	1500	4	180	B5	4EG180L4E-FA-BA-C34	CI	192.68
	894283	22	1500	4	180	B5	4EL180L4E-FA-BA-C34	ALU	212.00
	894295	30	1500	4	200	B3	4EG200L4E-PD-BA-C34	CI	258.36
	894293	30	1500	4	200	B5	4EG200L4E-FA-BA-C34	CI	258.36
	894302	37	1500	4	225	B3	4EG225S4D-PD-BA-C34	CI	327.02
	894300	37	1500	4	225	B5	4EG225S4D-FA-BA-C34	CI	327.02
	894309	45	1500	4	225	B3	4EG225M4E-PD-BA-C34	CI	357.51
	894307	45	1500	4	225	B5	4EG225M4E-FA-BA-C34	CI	357.51
	894316	55	1500	4	250	B3	4EG250M4E-PD-BA-C34	CI	461.05
894314	55	1500	4	250	B5	4EG250M4E-FA-BA-C34	CI	461.05	
894323	75	1500	4	280	B3	4EG280S4D-PD-BA-C34	CI	615.77	
894321	75	1500	4	280	B5	4EG280S4D-FA-BA-C34	CI	615.77	
894330	90	1500	4	280	B3	4EG280M4E-PD-BA-C34	CI	670.00	
894328	90	1500	4	280	B5	4EG280M4E-FA-BA-C34	CI	670.00	

Flanges

RE code	Type	Mounting	Frame size
891855	Flange	B5	63
891856	Flange	B5	71
891857	Flange	B5	80
891858	Flange	B5	90
891859	Flange	B5	100
891860	Flange	B5	112
891861	Flange	B5	132
891862	Flange	B5	160
891863	Flange	B5	180
891864	Flange	B5	200
891865	Flange	B5	225
891866	Flange	B5	250
891867	Flange	B5	280
891868	Flange	B14	63
891869	Flange	B14	71
891870	Flange	B14	80
891871	Flange	B14	90
891872	Flange	B14	100
891873	Flange	B14	112
891874	Flange	B14	132
891875	Flange	B14	160

Supplied in Aluminium

 Denotes cast iron

Feet (supplied in pack of two)

RE code	Type	Frame size
891876	Feet	63
891877	Feet	71
891878	Feet	80
891879	Feet	90
891880	Feet	100
891881	Feet	112
891882	Feet	132
891883	Feet	160
891884	Feet	280

Base plates

			Dimensional data														
RE code	Product description	To suit motor sizes	A	B	C	D	E	F	G	H	L	M	O	P	SW	Q	W. kg
864455	MOTOR BASES 270	63-112	270	195	20	24	50	25	10.5	33	70	43	26	98	19	3	3
864456	MOTOR BASES 307	90-112	307	213	20	24	50	25	10.5	33	70	65	24	108	19	3	3.2
864457	MOTOR BASES 340	90-132	340	290	27	27	62	30	12.5	40	95	90	38	165	22	4	6.3
864458	MOTOR BASES 430	90-160	430	290	27	27	62	29	12.5	40	95	90	38	165	22	4	7.5
864459	MOTOR BASES 490	160-180	490	410	40	27	60	30	15	40	95	193	48.5	284	22	4	10.8

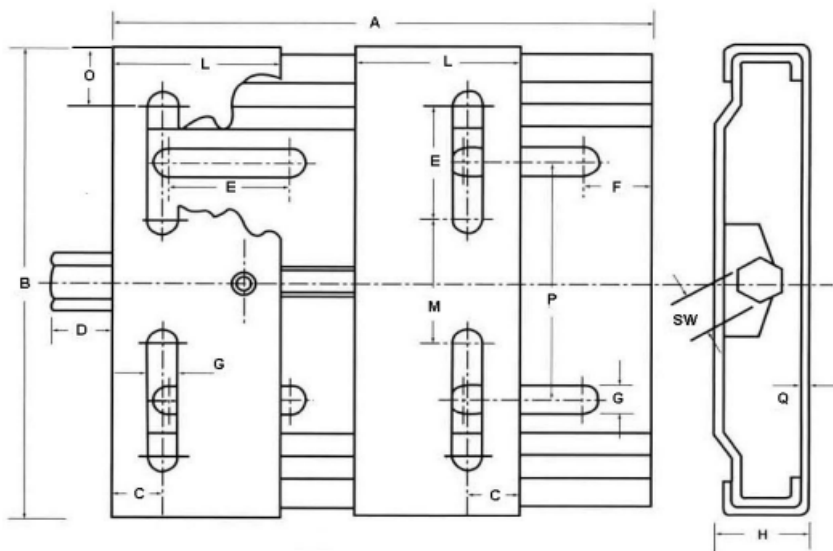



Technical information

2 pole 400V 50Hz 3000 RPM

Duty cycle: S1 (continuous operation)
Insulation class: F (155°C)
Temperature rise: B (80°C)

Voltage	Type	Rated values									Starting values		Break down torque	Moment of inertia	B3 motor weight	Sound pressure level
		P	S	FS	C	T	Power factor	Efficiency % η			Current	Torque				
		kW	RPM		A	Nm	Cos Φ	4/4	3/4	1/2	I_A/I_N	M_A/M_N				
230/400	2EL063M2A	0,18	2800	63	0,50	0,61	0,77	67,5	66,0	62,0	4,5	2,9	3,0	0,00012	3,80	51
	2EL063M2B	0,25	2800	63	0,67	0,85	0,78	69,0	68,0	63,5	4,5	2,7	3,0	0,00015	4,20	51
	2EL071M2A	0,37	2790	71	0,90	1,26	0,80	74,2	74,5	72,5	5,0	2,5	2,8	0,00031	5,50	54
	2EL071M2B	0,55	2790	71	1,27	1,88	0,82	75,8	77,0	76,0	5,0	2,8	2,9	0,00037	6,30	54

4 pole 400V 50Hz 1500 RPM

Voltage	Type	Rated values									Starting values		Break down torque	Moment of inertia	B3 motor weight	Sound pressure level
		P	S	FS	C	T	Power factor	Efficiency % η			Current	Torque				
		kW	RPM		A	Nm	Cos Φ	4/4	3/4	1/2	I_A/I_N	M_A/M_N				
230/400	2EL063M4B	0,12	1385	63	0,40	0,83	0,72	60,1	60,5	54,5	3,0	2,2	2,3	0,00018	3,60	42
	2EL063M4C	0,18	1390	63	0,56	1,24	0,72	64,7	65,8	61,5	3,0	2,2	2,3	0,00022	4,20	42
	2EL071M4B	0,25	1425	71	0,71	1,68	0,69	74,0	73,5	70,5	4,4	2,0	3,0	0,00067	5,90	46
	2EL071M4C	0,37	1425	71	1,00	2,47	0,70	76,1	75,5	71,5	4,6	2,0	3,0	0,00082	6,70	46
	2EL080M4B	0,55	1440	80	1,45	3,65	0,71	77,1	76,7	75,0	5,2	2,0	3,0	0,00175	9,70	50

P=Power S=Speed C=Current Torque=Torque FS=Frame size

UL approved motors have  logo on nameplate
See pages 4 & 5 for how to select the correct motor

6 pole 400V 50Hz 1000 RPM

Duty cycle: S1 (continuous operation)
 Insulation class: F (155°C)
 Temperature rise: B (80°C)



Voltage	Type	Rated values									Starting values		Break down torque	Moment of inertia	B3 motor weight	Sound pressure level
		P	S	FS	C	T	Power factor	Efficiency % η			Current	Torque				
		kW	RPM		A	Nm	Cos Φ	4/4	3/4	1/2	I_s/I_N	M_s/M_N				
230/400	2EL071M6B	0,18	920	71	0,60	1,87	0,67	64,5	63,0	57,0	3,2	1,9	2,3	0,00076	5,90	42
	2EL071M6C	0,25	920	71	0,78	2,59	0,69	66,5	66,0	61,0	3,3	1,9	2,3	0,00096	6,60	42
	2EL080M6A	0,37	925	80	1,08	3,82	0,69	71,4	71,5	70,0	4,0	2,0	2,6	0,00176	9,10	45
	2EL080M6B	0,55	932	80	1,50	5,64	0,72	73,5	74,0	71,0	4,2	2,1	2,6	0,00202	9,90	45

P=Power S=Speed C=Current Torque=Torque FS=Frame size

UL approved motors have  logo on nameplate
 See pages 4 & 5 for how to select the correct motor

2 pole 400V 50Hz 3000 RPM

Duty cycle: S1 (continuous operation)
 Insulation class: F (155°C)
 Temperature rise: B (80°C)



Voltage	Type	Rated values									Starting values		Break down torque	Moment of inertia	B3 motor weight	Sound pressure level
		P	S	FS	C	T	Power factor	Efficiency % η			Current	Torque				
		kW	RPM		A	Nm	Cos Φ	4/4	3/4	1/2	I_A/I_N	M_A/M_N				
230/400	3EL080M2B	0,75	2880	80	1,59	2,49	0,84	80,7	82,0	81,5	6,7	3,0	3,6	0,00103	9,6	54
	3EL080M2C	1,10	2880	80	2,26	3,64	0,85	82,7	83,0	82,4	6,8	3,1	3,8	0,00124	10,9	54
	3EL090S2B	1,50	2900	90	2,97	4,94	0,86	84,8	85,4	84,2	7,6	3,1	3,9	0,00178	15,6	59
	3EL090L2C	2,20	2900	90	4,25	7,24	0,87	85,9	86,8	86,1	7,2	3,0	3,8	0,00221	17,0	59
	3EL100L2C	3,00	2910	100	5,58	9,85	0,89	87,1	87,6	86,9	7,9	3,0	4,1	0,00450	23,3	62
400/690	3EL112M2C	4,00	2915	112	7,28	13,1	0,90	88,1	88,8	88,2	7,5	2,6	3,9	0,00618	29,1	65
	3EL132S2B	5,50	2945	132	9,90	17,8	0,90	89,2	89,0	88,6	8,9	2,9	3,9	0,01732	44,4	67
	3EL132S2C	7,50	2945	132	13,2	24,3	0,91	90,1	90,5	89,7	8,4	2,6	4,0	0,02104	51,5	67
	3EL160M2B	11,0	2950	160	19,7	35,6	0,88	91,2	91,0	90,5	8,0	2,6	3,9	0,03318	79,7	69
	3EL160M2C	15,0	2950	160	26,5	48,6	0,89	91,9	92,1	91,6	8,9	3,1	4,2	0,03913	86,0	69
	3EL160L2D	18,5	2945	160	31,7	60,0	0,91	92,4	92,7	92,3	8,9	3,1	4,2	0,04409	96,8	69
	3EG180M2B	22,0	2957	180	38,1	71,1	0,90	92,7	92,9	92,0	8,6	2,6	3,9	0,06299	178	70
	3EG200L2B	30,0	2970	200	52,0	96,5	0,89	93,6	93,8	93,6	8,9	3,2	3,5	0,16168	245	72
	3EG200L2C	37,0	2970	200	62,6	119	0,91	93,7	93,8	93,4	9,3	3,2	3,4	0,17458	270	72
	3EG225M2C	45,0	2975	225	75,6	144	0,91	94,3	94,6	94,0	9,8	3,5	3,9	0,25353	335	74
	3EG250M2C	55,0	2970	250	93,3	177	0,90	94,4	94,8	94,5	8,9	3,3	3,4	0,38000	422	75

UL approved motors have  logo on nameplate

See pages 4 & 5 for how to select the correct motor

P=Power S=Speed C=Current Torque=Torque FS=Frame size

UL approved motors have  logo on nameplate

See pages 4 & 5 for how to select the correct motor

4 pole 400V 50Hz 1500 RPM

Duty cycle: S1 (continuous operation)
 Insulation class: F (155°C)
 Temperature rise: B (80°C)



Voltage	Type	Rated values									Starting values		Break down torque M_k/M_N	Moment of inertia kgm ²	B3 motor weight kg	Sound pressure level dB (A)
		P	S	FS	C	T	Power factor	Efficiency % η			Current	Torque				
		kW	RPM		A	Nm	Cos Φ	4/4	3/4	1/2	I_A/I_N	M_A/M_N				
230/400	3EL080M4D	0,75	1450	80	1,77	4,94	0,74	82,5	82,3	80,0	6,2	2,5	3,4	0,00227	11,6	50
	3EL090S4C	1,10	1450	90	2,46	7,25	0,76	84,5	84,3	82,0	7,0	2,6	3,6	0,00355	16,3	51
	3EL090L4D	1,50	1445	90	3,30	9,91	0,77	85,3	85,2	83,0	7,2	2,8	3,8	0,00411	18,0	51
	3EL100L4C	2,20	1450	100	4,65	14,5	0,79	86,7	87,2	86,0	7,2	2,8	3,6	0,00775	24,4	53
	3EL100L4D	3,00	1450	100	6,26	19,8	0,79	87,7	88,0	87,0	7,2	2,8	3,6	0,00888	26,7	53
400/690	3EL112M4D	4,00	1460	112	8,05	26,2	0,81	88,6	88,4	87,5	7,4	2,8	3,8	0,01437	33,9	58
	3EL132S4C	5,50	1465	132	10,9	36,0	0,81	89,6	90,2	90,0	7,0	3,0	3,4	0,03059	53,4	61
	3EL132M4D	7,50	1465	132	14,4	48,9	0,83	90,4	90,4	89,4	7,9	3,0	3,4	0,03418	59,5	61
	3EL160M4C	11,0	1465	160	21,0	71,7	0,83	91,5	92,1	91,7	7,6	2,8	3,3	0,07011	89,2	63
	3EL160L4E	15,0	1465	160	28,7	97,8	0,82	92,1	92,4	91,9	7,8	2,8	3,6	0,08579	97,5	63
	3EG180M4C	18,5	1475	180	35,0	120	0,82	92,6	93,2	92,9	7,7	3,0	3,3	0,12901	173	64
	3EG180L4D	22,0	1470	180	41,4	143	0,82	93,0	93,7	93,7	8,0	3,0	3,4	0,14667	187	64
	3EG200L4D	30,0	1475	200	54,5	194	0,85	93,6	94,1	94,0	8,0	3,0	3,4	0,28413	258	65
	3EG225S4C	37,0	1478	225	65,7	239	0,87	93,9	94,5	94,5	8,3	3,2	3,3	0,38229	320	66
	3EG225M4D	45,0	1477	225	80,0	291	0,86	94,2	94,7	94,7	8,6	3,3	3,2	0,44100	352	67
	3EG250M4D	55,0	1482	250	95,3	354	0,88	94,6	95,1	95,2	8,7	3,3	3,2	0,73000	470	68

P=Power S=Speed C=Current Torque=Torque FS=Frame size

UL approved motors have  logo on nameplate
 See pages 4 & 5 for how to select the correct motor

6 pole 400V 50Hz 1000 RPM

Duty cycle: S1 (continuous operation)
Insulation class: F (155°C)
Temperature rise: B (80°C)

Voltage	Type	Rated values									Starting values		Break down torque	Moment of inertia	B3 motor weight	Sound pressure level
		P	S	FS	C	T	Power factor	Efficiency % η			Current	Torque				
		kW	RPM		A	Nm	Cos Φ	4/4	3/4	1/2	I_A/I_N	M_A/M_N				
230/400	3EL090S6B	0,75	945	90	1,96	7,58	0,70	78,9	79,2	77,6	4,7	2,2	2,7	0,00354	14,6	46
	3EL090L6C	1,10	940	90	2,75	11,2	0,71	81,0	80,8	79,4	5,0	2,2	2,7	0,00428	17,0	46
	3EL100L6B	1,50	955	100	3,50	15,0	0,75	82,5	82,7	81,4	5,3	2,1	2,8	0,00821	22,5	50
	3EL112M6B	2,20	960	112	4,95	21,9	0,76	84,3	84,5	83,5	5,5	2,2	3,0	0,01319	27,2	56
400/690	3EL132S6B	3,00	970	132	6,55	29,4	0,77	85,6	85,5	84,5	6,2	2,1	3,0	0,03051	46,5	58
	3EL132M6C	4,00	970	132	8,52	39,4	0,78	86,8	87,0	85,5	6,2	2,2	3,0	0,03493	51,0	58
	3EL132M6D	5,50	965	132	11,6	54,4	0,78	88,0	88,9	88,5	6,2	2,2	3,0	0,03934	56,0	58
	3EL160M6D	7,50	972	160	15,6	73,7	0,78	89,1	89,4	88,4	6,3	2,6	3,0	0,07870	96,0	61
	3EL160L6E	11,0	972	160	22,9	108	0,77	90,3	90,9	90,5	6,6	2,9	3,3	0,08580	104	62
	3EG180L6E	15,0	975	180	30,8	147	0,77	91,2	91,6	91,0	6,7	2,9	3,1	0,15264	187	63
	3EG200L6C	18,5	977	200	36,4	181	0,80	91,7	91,8	91,8	6,1	2,6	2,6	0,36100	225	64
	3EG200L6D	22,0	978	200	42,5	215	0,81	92,2	92,9	93,0	6,2	2,6	2,7	0,39355	245	64
	3EG225S6C	30,0	985	225	57,6	291	0,81	92,9	92,9	92,6	6,6	2,6	2,7	0,60000	326	65
	3EG250M6C	37,0	988	250	68,8	358	0,83	93,4	93,6	93,5	6,8	2,9	2,8	0,82000	432	65
	3EG280S6B	45,0	989	280	83,5	435	0,83	93,7	93,9	93,2	6,8	2,9	2,8	1,45000	540	65
	3EG280M6C	55,0	989	280	102	531	0,83	94,1	94,4	93,5	6,9	2,9	2,8	1,65000	575	65

P=Power S=Speed C=Current Torque=Torque FS=Frame size

UL approved motors have  logo on nameplate
See pages 4 & 5 for how to select the correct motor

2 pole 50Hz 3000 RPM

Duty cycle: S1 (continuous operation)
Insulation class: F (155°C)
Temperature rise: B (80°C)



Voltage	Type	Rated values								Starting values		Break down torque	Moment of inertia	B3 motor weight	Sound pressure level
		P	S	C	T	Power factor	Efficiency % η			Current	Torque				
		kW	RPM	A	Nm	cos Φ	4/4	3/4	1/2	I_A/I_N	M_A/M_N				
230/400	4EL071M2B	0,37	2825	0,83	1,25	0,82	78,1	78,3	76,5	5,7	2,8	3,2	0,00037	6,50	58
	4EL071 M2C	0,55	2825	1,17	1,86	0,83	81,5	81,9	79,5	6,2	2,9	3,5	0,00046	7,50	58
	4EL080M2C	0,75	2875	1,56	2,49	0,83	83,5	84,0	81,0	6,8	2,9	3,5	0,00124	11,0	59
	4EL080M2D	1,10	2880	2,19	3,65	0,85	85,2	85,5	84,9	7,5	2,9	3,7	0,00135	12,0	59
	4EL090S2C	1,50	2900	2,95	4,94	0,85	86,5	86,9	85,7	7,8	2,9	3,7	0,00221	17,2	64
	4EL090L2D	2,20	2900	4,20	7,24	0,86	88,0	88,5	87,6	8,2	3,0	3,8	0,00234	20,0	64
	4EL100L2D	3,00	2910	5,50	9,85	0,88	89,1	89,5	88,5	8,5	3,0	4,0	0,00503	25,9	67
400/690	4EL11 2M2D	4,00	2940	7,30	13,0	0,88	90,0	90,3	89,7	8,7	3,0	4,2	0,00734	32,5	70
	4EL132S2C	5,50	2945	9,60	17,8	0,91	90,9	90,9	90,0	8,9	3,2	4,2	0,02104	52,5	72
	4EL132S2D	7,50	2945	13,0	24,5	0,91	91,7	92,2	91,8	8,5	3,2	4,2	0,02290	54,0	72
	4EL160M2C	11,0	2950	18,9	35,6	0,91	92,6	92,7	91,2	8,5	3,3	4,3	0,03913	133	74
	4EL160M2D	15,0	2950	25,6	48,6	0,91	93,3	93,6	92,8	8,5	3,3	4,3	0,04409	135	74
	4EL160L2E	18,5	2955	31,4	59,8	0,91	93,7	93,8	92,9	8,7	3,2	4,3	0,05000	145	74
	4EG180M2C	22,0	2960	37,2	71,1	0,91	94,0	94,4	93,5	8,9	3,0	4,0	0,07000	195	74
	4EG200L2C	30,0	2970	51,0	96,5	0,90	94,5	94,7	94,0	8,3	3,2	3,7	0,17500	272	74
	4EG200L2D	37,0	2970	63,3	120	0,89	94,8	95,0	94,2	8,3	3,2	4,0	0,20000	295	74
	4EG225M2D	45,0	2975	76,0	145	0,90	95,0	95,2	94,9	9,0	3,4	4,2	0,29000	385	74
	4EG250M2D	55,0	2975	90,5	177	0,92	95,3	95,5	94,9	8,2	3,4	3,7	0,52000	520	74
	4EG 280S2C	75,0	2982	124	240	0,91	95,6	95,6	95,2	7,7	2,7	3,2	0,98000	640	76
	4EG280M2D	90,0	2985	149	288	0,91	95,8	95,9	95,0	7,7	2,8	3,5	1,10000	720	77
	4EG315S2C	110	2985	182	352	0,91	96,0	96,0	95,7	7,8	2,6	3,3	1,60000	905	77
	4EG315M2D	132	2986	217	422	0,91	96,2	96,3	96,0	8,0	2,6	3,3	2,00000	1085	77
	4EG315L2E	160	2986	260	542	0,92	96,3	96,5	96,0	8,0	2,7	3,4	2,20000	4195	78
	4EG315L2F	200	2987	325	639	0,92	96,5	96,7	96,2	8,1	2,9	3,5	2,70000	1310	78

P=Power S=Speed C=Current Torque=Torque FS=Frame size

UL approved motors have  logo on nameplate
See pages 4 & 5 for how to select the correct motor

4 pole 50Hz 1500 RPM

Duty cycle: S1 (continuous operation)
Insulation class: F (155°C)
Temperature rise: B (80°C)

Voltage	Type	Rated values								Starting values		Break down torque	Moment of inertia	B3 motor weight	Sound pressure level
		P	S	C	T	Power factor	Efficiency % η			Current	Torque				
		kW	RPM	A	Nm	Cos Φ	4/4	3/4	1/2	I_A/I_N	M_A/M_N				
400/690	4EL132S4D	5,50	1470	11,1	35,7	0,78	91,9	91,8	90,6	7,7	3,8	3,7	0,03418	60,0	61
	4EL132M4F	7,50	1470	14,6	48,7	0,80	92,6	92,7	91,5	7,7	3,8	4,0	0,04316	72,8	62
	4EL160M4E	11,0	1470	21,0	71,5	0,81	93,3	93,5	93,3	7,7	3,0	3,6	0,08600	137	64
	4EL160L4F	15,0	1475	28,9	97,5	0,80	93,9	94,1	93,8	8,7	3,7	4,3	0,12000	152	64
	4EG180M4D	18,5	1475	34,6	120	0,82	94,2	94,4	94,0	8,0	3,1	3,5	0,14700	190	64
	4EG180L4E	22,0	1475	41,0	142	0,82	94,5	94,7	94,2	8,2	3,2	3,8	0,17000	212	64
	4EG 200L4E	30,0	1480	53,0	194	0,86	94,9	95,3	95,2	8,3	3,3	3,8	0,35000	310	64
	4EG225S4D	37,0	1480	65,0	239	0,86	95,2	95,7	95,0	8,1	3,3	3,3	0,44100	355	70
	4EG225M4E	45,0	1480	79,2	290	0,86	95,4	95,6	95,6	8,2	3,5	3,3	0,52000	405	70
	4EG250M4E	55,0	1485	94,3	354	0,88	95,7	96,0	96,0	8,3	3,3	3,4	1,05000	522	70
	4EG 280S4D	75,0	1487	127	482	0,89	96,0	96,3	96,2	7,6	3,0	3,2	1,50000	670	70
	4EG280M4E	90,0	1488	152	578	0,89	96,1	96,3	96,3	7,6	3,1	3,2	1,95000	790	71
	4EG315S4D	110	1490	187	705	0,88	96,3	96,5	96,0	7,8	2,8	3,3	2,80000	975	73
	4EG315M4E	132	1490	225	846	0,88	96,4	96,7	96,2	8,0	2,9	3,3	3,30000	1050	73
	4EG315L4F	160	1490	269	1026	0,89	96,6	96,9	96,5	8,2	3,1	3,4	4,40000	1250	76
4EG315L4G	200	1490	335	1282	0,89	96,7	97,0	96,6	8,3	3,3	3,5	5,20000	1490	76	

P=Power S=Speed C=Current Torque=Torque FS=Frame size

UL approved motors have  logo on nameplate
See pages 4 & 5 for how to select the correct motor



Dimensions

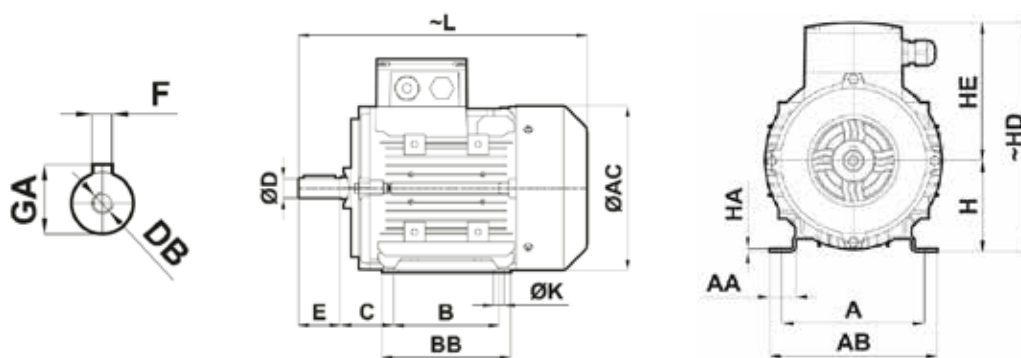

Frame size	No. of poles	D ^[1]	E	L	AC	H ^[2]	HE	HD	F	GA	DB	C	ØK	B	BB	HA	AA	A	AB
063M	2-4-6	11	23	213	119	63	97	160	4	12,5	M4	40	7	80	104	3	18	100	115
071M	2-4-6	14	30	244	137	71	112	183	5	16	M5	45	7	90	110	3	19	112	128
080M	2-4-6	19	40	274	155	80	123	203	6	21,5	M6	50	10	100	122	3	25	125	148
090S	2-4-6	24	50	325	176	90	132	222	8	27	M8	56	10	100	151	4	27	140	167
090L	2-4-6	24	50	325	176	90	132	222	8	27	M8	56	10	125	151	4	27	140	167
100L	2-4-6	28	60	370,5	193	100	149	249	8	31	M10	63	12	140	170	4	31	160	192
112M	2-4-6	28	60	390	215	112	161	273	8	31	M10	70	12	140	177	4	36	190	217
132S	2-4-6	38	80	495	257	132	181	313	10	41	M12	89	12	140	212	5	34	216	254
132M	2-4-6	38	80	495	257	132	181	313	10	41	M12	89	12	178	212	5	34	216	254
132L	2-4-6	38	80	543	257	132	181	313	10	41	M12	89	12	178	212	5	34	216	254
160M	2-4-6	42	110	605	316	160	224	384	12	45	M16	108	14,5	210	323	15	65	254	295
160L	2-4-6	42	110	605	316	160	224	384	12	45	M16	108	14,5	254	323	15	65	254	295
180M	2-4-6	48	110	697	348	180	250	430	14	51,5	M16	121	14,5	241	319	15	50	279	326
180L	2-4-6	48	110	697	348	180	250	430	14	51,5	M16	121	14,5	279	319	15	50	279	326
200L	2-4-6	55	110	740	396	200	287	487	16	59	M20	133	18,5	305	350	18	62,5	318	381
225S	2	55	110	795	438	225	315,5	540,5	16	59	M20	149	18,5	286	370	20	70	356	428
	4-6	60	140	825					18	64									
225M	2	55	110	795	438	225	315,5	540,5	16	59	M20	149	18,5	311	370	20	70	356	428
	4-6	60	140	825					18	64									
250M	2	60	140	896	481	250	335	585	18	64	M20	168	24	349	420	32,5	80	406	490
	4-6	65	140	896					18	69									
280S	2	65	140	1019,5	547	280	402	682	18	69	M20	190	24	368	500	36	121	457	558
	4-6	75	140	1019,5					20	79,5									
280M	2	65	140	1019,5	547	280	402	682	18	69	M20	190	24	419	500	36	121	457	558
	4-6	75	140	1019,5					20	79,5									

[1] Tolerance "j6" up to 28mm, "k6" from 28mm to 48mm, "m6" over 48mm TS EN 50347

2 pole - 2880 RPM

4 pole - 1500 RPM

6 pole - 1000 RPM

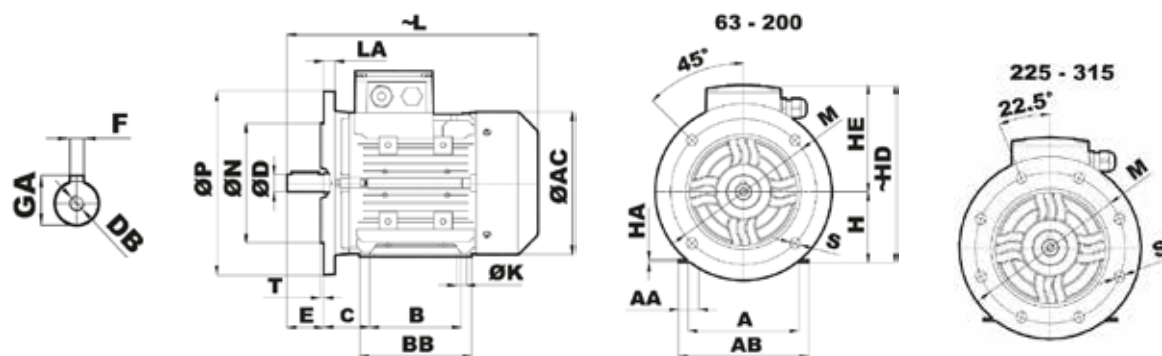

Frame size	No. of poles	D ^[1]	E	N ^[2]	P	T	LA	L	AC	S	M	H ^[3]	HE	HD	F	GA	DB	C	ØK	B	BB	HA	AA	A	AB
063M	2-4-6	11	23	95	140	3	8	213	119	10	115	63	97	160	4	12,5	M4	40	7	80	104	3	18	100	115
071M	2-4-6	14	30	110	160	3,5	8	244	137	10	130	71	112	183	5	16	M5	45	7	90	110	3	19	112	128
080M	2-4-6	19	40	130	200	3,5	12	274	155	12	165	80	123	203	6	21,5	M6	50	10	100	122	3	25	125	148
090S	2-4-6	24	50	130	200	3,5	12	325	176	12	165	90	132	222	8	27	M8	56	10	100	151	4	27	140	167
090L	2-4-6	24	50	130	200	3,5	12	325	176	12	165	90	132	222	8	27	M8	56	10	125	151	4	27	140	167
100L	2-4-6	28	60	180	250	4	15	370,5	193	14,5	215	100	149	249	8	31	M10	63	12	140	170	4	31	160	192
112M	2-4-6	28	60	180	250	4	15	390	215	14,5	215	112	161	273	8	31	M10	70	12	140	177	4	36	190	217
132S	2-4-6	38	80	230	300	4	20	495	257	14,5	265	132	181	313	10	41	M12	89	12	140	212	5	34	216	254
132M	2-4-6	38	80	230	300	4	20	495	257	14,5	265	132	181	313	10	41	M12	89	12	178	212	5	34	216	254
132L	2-4-6	38	80	230	300	4	20	543	257	14,5	265	132	181	313	10	41	M12	89	12	178	212	5	34	216	254
160M	2-4-6	42	110	250	350	5	20	605	316	18,5	300	160	224	384	12	45	M16	108	14,5	210	323	15	65	254	295
160L	2-4-6	42	110	250	350	5	20	605	316	18,5	300	160	224	384	12	45	M16	108	14,5	254	323	15	65	254	295
180M	2-4-6	48	110	250	350	5	14	697	348	18,5	300	180	250	430	14	51,5	M16	121	14,5	241	319	15	50	279	326
180L	2-4-6	48	110	250	350	5	14	697	348	18,5	300	180	250	430	14	51,5	M16	121	14,5	279	319	15	50	279	326
200L	2-4-6	55	110	300	400	5	14	740	396	18,5	350	200	287	487	16	59	M20	133	18,5	305	350	18	62,5	318	381
225S	2	55	110	350	450	5	20	795	438	18,5	400	225	315,5	540,5	16	59	M20	149	18,5	286	370	20	70	356	428
	4-6	60	140					825							18	64									
225M	2	55	110	350	450	5	20	795	438	18,5	400	225	315,5	540,5	16	59	M20	149	18,5	311	370	20	70	356	428
	4-6	60	140					825							18	64									
250M	2	60	140	450	550	5	20	896	481	18,5	500	250	335	585	18	64	M20	168	24	349	420	32,5	80	406	490
	4-6	65	140					69							69										
280S	2	65	140	450	550	5	20	1019,5	547	18,5	500	280	402	682	18	69	M20	190	24	368	500	36	121	457	558
	4-6	75	140					79,5							79,5										
280M	2	65	140	450	550	5	20	1019,5	547	18,5	500	280	402	682	18	69	M20	190	24	419	500	36	121	457	558
	4-6	75	140					79,5							79,5										

[1] Tolerance "j6" up to 28mm, "k6" from 28mm to 48mm, "m6" over 48mm TS EN 50347

2 pole - 2880 RPM

4 pole - 1500 RPM

6 pole - 1000 RPM

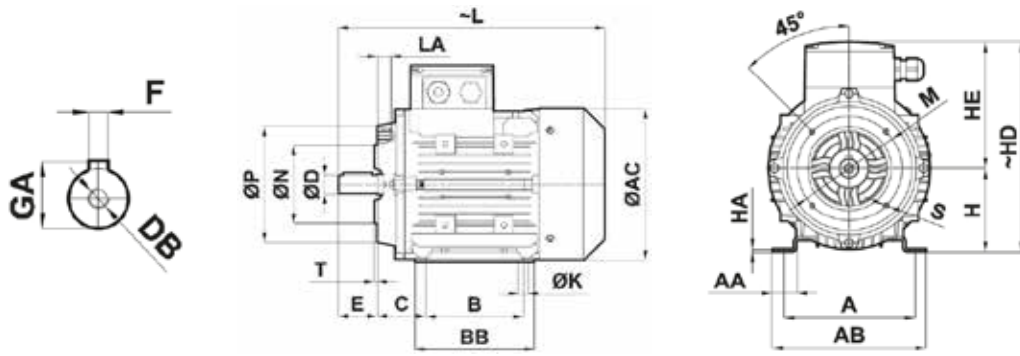

Frame size	No. of poles	D ^[1]	N ^[2]	P	E	T	LA	L	AC	S	M	H ^[3]	HE	HD	F	GA	DB	C	ØK	B	BB	HA	AA	A	AB
063M	2-4-6	11	60	90	23	2,5	10	213	119	M5	75	63	97	160	4	12,5	M4	40	7	80	104	3	18	100	115
071M	2-4-6	14	70	105	30	2,5	12	244	137	M6	85	71	112	183	5	16	M5	45	7	90	110	3	19	112	128
080M	2-4-6	19	80	118,5	40	3	12	274	155	M6	100	80	123	203	6	21,5	M6	50	10	100	122	3	25	125	148
090S	2-4-6	24	95	136,5	50	3	15	325	176	M8	115	90	132	222	8	27	M8	56	10	100	151	4	27	140	167
090L	2-4-6	24	95	136,5	50	3	15	325	176	M8	115	90	132	222	8	27	M8	56	10	125	151	4	27	140	167
100L	2-4-6	28	110	159,5	60	3,5	17	370,5	193	M8	130	100	149	249	8	31	M10	63	12	140	170	4	31	160	192
112M	2-4-6	28	110	159,5	60	3,5	17	390	215	M8	130	112	161	273	8	31	M10	70	12	140	177	4	36	190	217
132S	2-4-6	38	130	200	80	3,5	20	495	257 M1	0	165	132	181	313	10	41	M12	89	12	140	212	5	34	216	254
132M	2-4-6	38	130	200	80	3,5	20	495	257 M1	0	165	132	181	313	10	41	M12	89	12	178	212	5	34	216	254
132L	2-4-6	38	130	200	80	3,5	20	543	257 M1	0	165	132	181	313	10	41	M12	89	12	178	212	5	34	216	254
160M	2-4-6	42	180	250	110	4	23	605	316 M1	2	215	160	224	384	12	45	M16	108	14,5	210	323	15	65	254	295
160L	2-4-6	42	180	250	110	4	23	605	316 M1	2	215	160	224	384	12	45	M16	108	14,5	254	323	15	65	254	295

[1] Tolerance "j6" up to 28mm, "k6" over 28mm TS EN 50347

[2] Tolerance "j6" TS EN 50347

[3] Tolerance "-0.5mm" TS EN 50347

2 pole - 2880 RPM

4 pole - 1500 RPM

6 pole - 1000 RPM

IEC/EN/UL compatibility

All of standard Mecaline motors are designed, manufactured and tested according to the IEC and EN standards given below. All motors are to IEC 60034 specifications.

Electromagnetic compatibility	EN 55014-1	EN 61000-3-2	EN 61000-3-3
Rotating electrical machines - General requirements	UL 1004-1		
Motors and generators	CSA C22.2 No. 100		



All of our motors, which have that UL logo on nameplate are approved by UL and manufactured according to UL 1004-1 and CSA C22.2.

Mechanical construction

Mecaline motors from frame size 63-180 provide flexibility for different Mounting types through their detachable feet which can be mounted on three sides. This feature allows terminal box assembly on the desired side. Terminal box is on the top for standard motors. Cast iron motors of frame size 200-280 have fixed feet.

Motor size 63-180

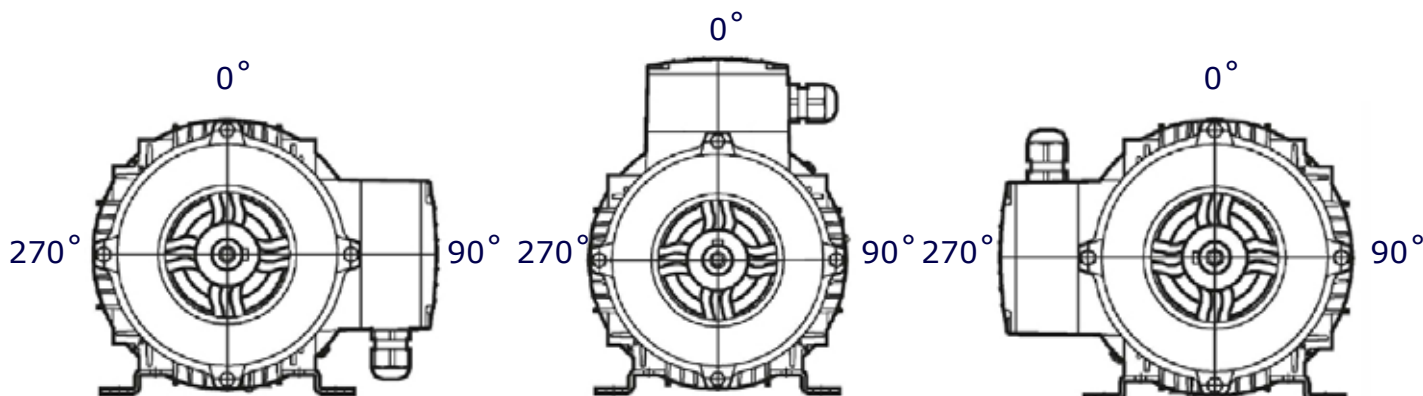

Additionally the housing and end shields are designed symmetrically for all the Frame sizes, so that the drive and non-drive side end shields can be replaced and the direction of the rotor shaft group can be changed. By making this end shields and rotor shaft group modifications, the user can have a motor with terminal box is at the non-drive side keeping the distance C according to the standards.

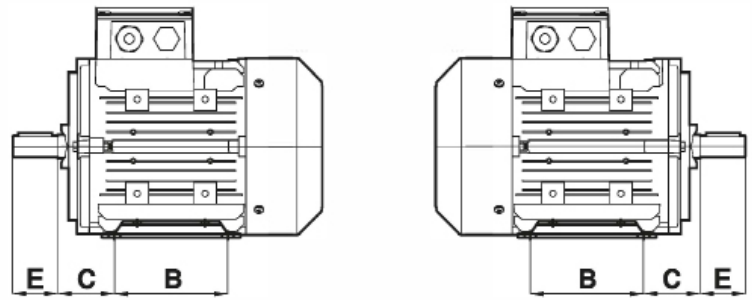

The raw materials that are used in our motors depending on the Frame size are listed below.

Frame size	Housing	End shield DE	End shield NDE	Terminal box and cover	Feet	Fan cover	Fan
63	Aluminium	Aluminium	Aluminium	Aluminium	Steel sheet	Steel sheet	Plastic
71	Aluminium	Aluminium	Aluminium	Aluminium	Steel sheet	Steel sheet	Plastic
80	Aluminium	Aluminium	Aluminium	Aluminium	Steel sheet	Steel sheet	Plastic
90	Aluminium	Aluminium	Aluminium	Aluminium	Steel sheet	Steel sheet	Plastic
100	Aluminium	Aluminium	Aluminium	Aluminium	Steel sheet	Steel sheet	Plastic
112	Aluminium	Aluminium	Aluminium	Aluminium	Steel sheet	Steel sheet	Plastic
132	Aluminium Cast iron	Aluminium Cast iron	Aluminium Cast iron	Aluminium Cast iron	Steel sheet Cast iron	Steel sheet	Plastic
160	Aluminium Cast iron	Aluminium Cast iron	Aluminium Cast iron	Aluminium Cast iron	Aluminium Cast iron	Steel sheet	Plastic
180	Cast iron	Cast iron	Cast iron	Cast iron	Cast iron	Steel sheet	Plastic
200	Cast iron	Cast iron	Cast iron	Cast iron	Cast iron	Steel sheet	Plastic
225	Cast iron	Cast iron	Cast iron	Cast iron	Cast iron	Steel sheet	Plastic
250	Cast iron	Cast iron	Cast iron	Cast iron	Cast iron	Steel sheet	Plastic
280	Cast iron	Cast iron	Cast iron	Cast iron	Cast iron	Steel sheet	Plastic

- Aluminium
- Steel sheet
- Plastic
- Aluminium Cast iron
- Steel sheet Cast iron
- Cast iron

Electrical construction

Standard Mecaline motors have insulation Class F while the temperature rise is Class B. This means the motors will have a longer service life and work under hard conditions.

Electrical connections

Cable gland and blind cap														
Frame size	063	071	080	090	100	112	132	160	180	200	225	250	280	
Cable glands	M16x1,5	M20x1,5			M25x1,5			2 x M32x1,5		2 x M40x1,5		2 x M50x1,5		2 x M63x1,5
Blind cap	M16x1,5				M25x1,5			-		-		-		-

Terminal connections														
Frame size	063	071	080	090	100	112	132	160	180	200	225	250	280	
Terminal size	M4				M5			M6			M8		M10	

The motors shall be connected in star or delta according to rated voltage given in their nameplate and the network voltage that they will be connected. For phase to phase 400V supply the motors with 230/400V nameplate values shall be connected in star and the motors with 400/690V nameplates values shall be connected in delta.

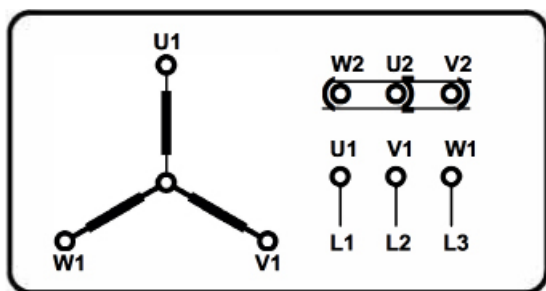

Y Star Connection

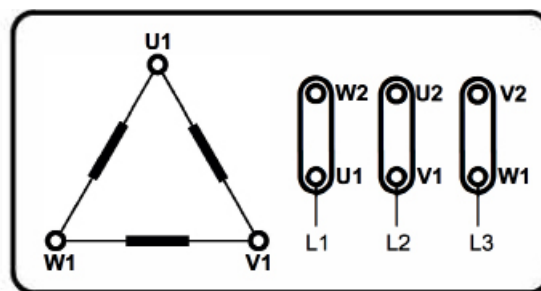

Δ Delta Connection

Motors at 60Hz network

Standard Mecaline motors that have been manufactured for 50 Hz power supply can be used at 60Hz network. The ratios given below indicate changes in the given rated values.

50 Hz rated voltage	60 Hz rated voltage	Rated speed	Rated power	Rated torque	Rated current	Starting torque	Break down torque	Starting current
230V	220V	1.193	1	0.84	0.97	0.77	0.8	0.8
400V	380V	1.193	1	0.84	0.97	0.77	0.8	0.8
400V	440V	1.20	1.16	0.97	0.98	0.87	0.9	0.9

Motors with variable speed drives

Standard Mecaline motors are suitable for variable speed drives. The frequency range that the motor can be driven with their fan is given below with blue line. If the motor will be driven in a wider range then a separately driven fan is necessary. By using a separately driven fan, the motors can be driven in the range defined by red line.

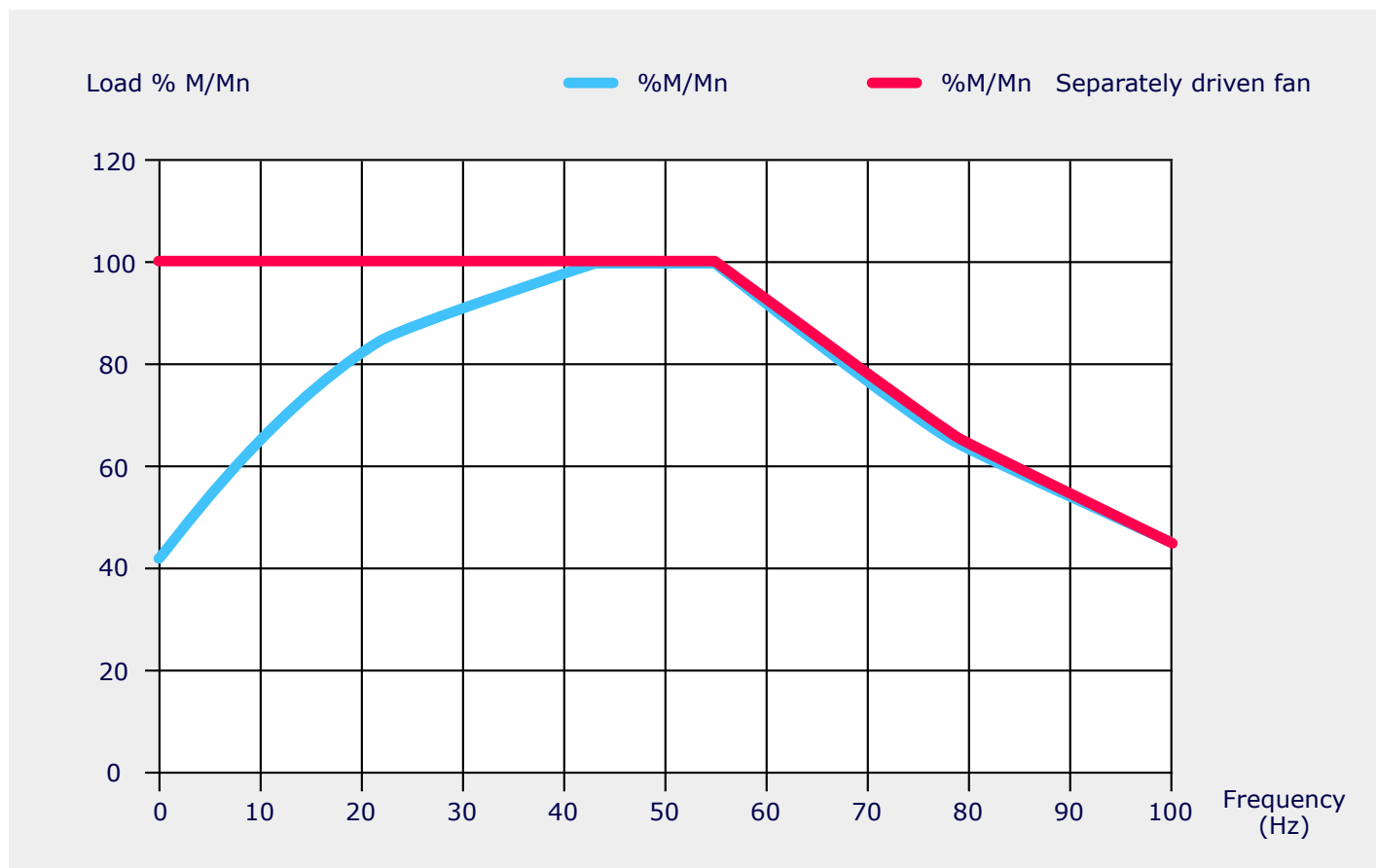

Motors in several environment conditions

Mecaline motors are designed to operate at ambient temperature up to 40°C according to IEC 60034-1. Rated output will change at the % ratings given below for different ambient temperatures.

Ambient temperature	< 30°C	35°C	40°C	45°C	50°C	55°C	60°C
% Power ratio	105	102	100	97	93	87	82

Winding insulation/temperature rise classes

All standard motors in the Mecaline motor range have F (155 ° C) class electrical insulation system. However, by means of its superior design features, the temperature rise of all standard motors remain within the Class B temperature rise limits when operating under rated conditions. Depending on the safety margin of the temperature rise class provided, our motors can provide 15% higher rated output power with a service factor of 1.15 (SF).

INSULATION CLASS

Maximum Winding Temperature

Tolerance

Limits of Winding Temperature

Ambient Temperature

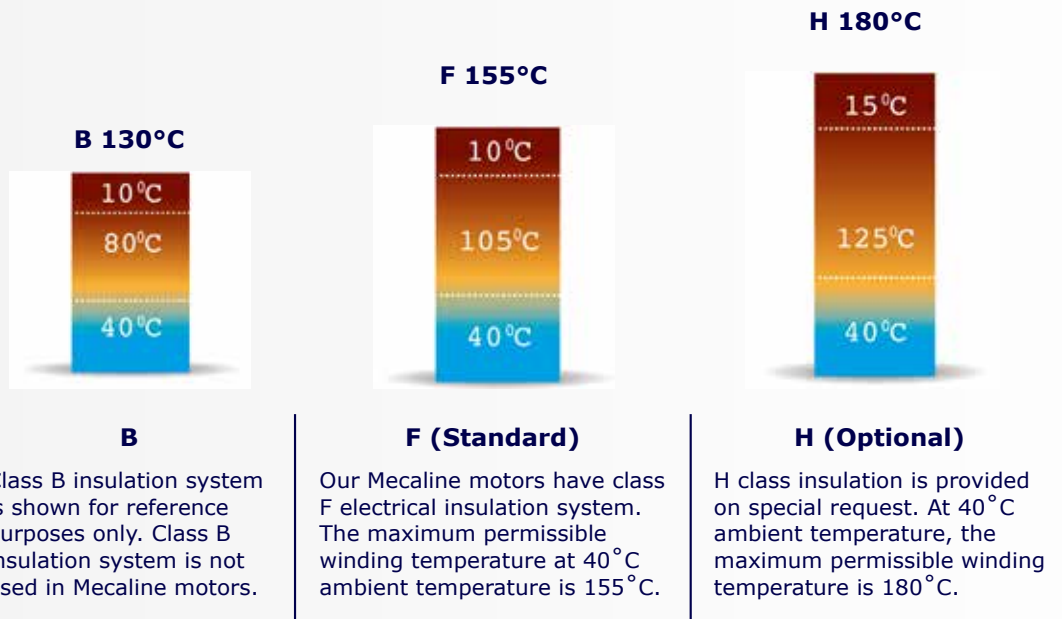

Protection classes

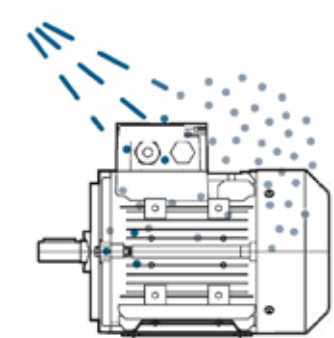

IP55 (Mecaline standard)

Limited protection against dust ingress and protected against low pressure water jets from any direction.



IP56

Limited protection against dust ingress and protected against high pressure water jets from any direction.

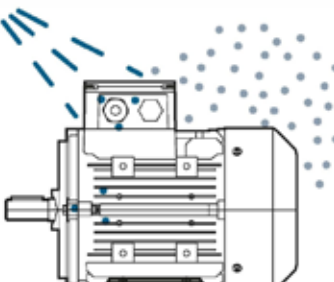

IP65

Totally protected against dust ingress and protected against low pressure water jets from any direction.









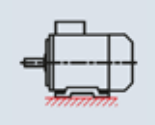
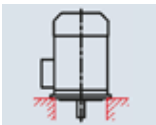
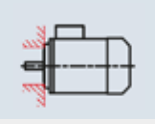

IP66

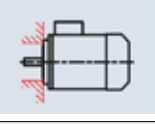
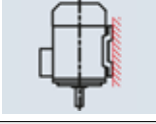
Totally protected against dust ingress and protected against high pressure water jets from any direction.

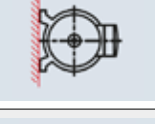
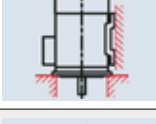
Construction types

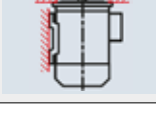
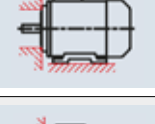
Mecaline motors are manufactured according to International Mounting Standard IEC 60034-7.

Mounting codes and diagrams according to IEC 60034-7					
Horizontal mounting codes			Vertical mounting codes		
	I	II		I	II
	IM B3	IM 1001		IM V1	IM 3011
	IM B5	IM 3001		IM V3	IM 3031
	IM B14	IM 3601		IM V5	IM 1011
	IM B7	IM 1061		IM V6	IM 1031
	IM B6	IM 1051		IM V15	IM 2011
	IM B8	IM 1071		IM V35	IM 2031
	IM B34	IM 2101			
	IM B35	IM 2001			

Bearings

Standard Mecaline motors are equipped with ball bearings with ZZ shields as listed below, according to Frame size. NU-NJ bearings are optional.

Frame size	Number of pole	Drive end bearing	Non drive end bearing
63	2-4-6	6201 ZZ	6201 ZZ
71	2-4-6	6202 ZZ	6202 ZZ
80	2-4-6	6204 ZZ	6204 ZZ
90	2-4-6	6205 ZZ	6205 ZZ
100	2-4-6	6206 ZZ	6206 ZZ
112	2-4-6	6206 ZZ	6206 ZZ
132	2-4-6	6208 ZZ	6208 ZZ
160	2-4-6	6309 ZZ	6209 ZZ
180	2-4-6	6310 ZZ	6210 ZZ
200	2-4-6	6312 ZZ	6212 ZZ
225	2-4-6	6313 ZZ	6213 ZZ
250	2-4-6	6315 ZZ	6215 ZZ
280	2 4-6	6315 6317	6315 6317

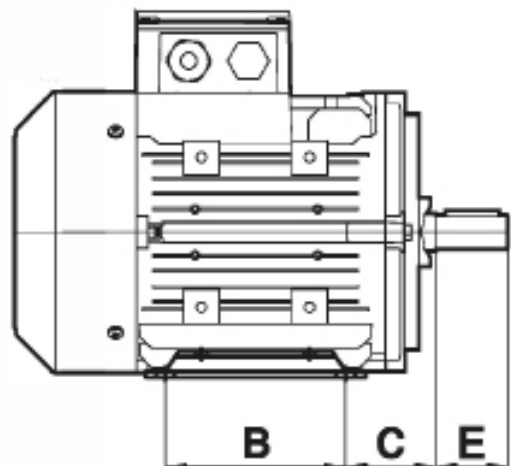
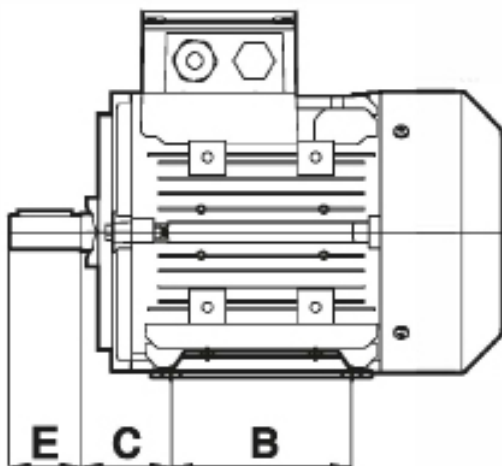

Radial loads

Radial Load (FR)

Radial load can be calculated according to below written formula. Calculated radial load must be below permissible radial loads given at tables.

$$F_R = k \cdot \frac{P}{D \cdot n} \cdot 10^7 \text{ (N)}$$

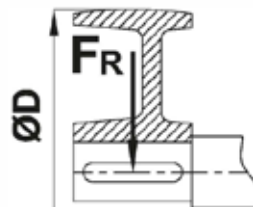

Correction of Permissible Radial Load

If the radial load is applied between points x_0 and x_{max} , the permissible radial load can be corrected with the following formula.

$$F_{r_x} = F_{r_0} - \frac{x}{E} (F_{r_0} - F_{r_{max}})$$

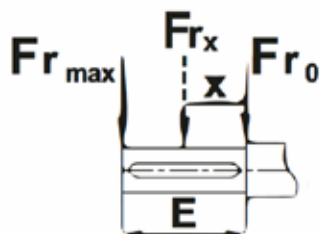

P: Motor Power (kW)

D: Pulley Diameter (mm)

n: Motor speed (RPM)

k: Radial load factor

- Spur Gears, chain drives with low speed = 2, 1
- Trigger Belts = 2,5
- V type belts = 5

FR < Fr_x: Calculated radial load must be below permissible radial loads given at tables.

F_a: Axial load

F_{r0}: Permissible radial load at shaft spigot.

F_{r max}: Permissible radial load at shaft end point.

Permissible loads are calculated for Lh10 20000 h bearing lifetimes according to ISO 281.

Radial loads

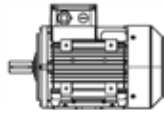

HORIZONTAL MOUNTING - Permissible Radial Loads Mounting Positions IM: B3, B5, B6, B7, B8, B14, B34, B35



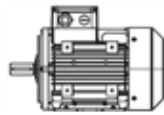

Frame size	Fa=0	
	 Fr [N]°	 Fr [N]max
2 Poles 3000 RPM	Fr [N]°	Fr [N]max
63	350	300
71	380	340
80	640	550
90	750	660
100	1050	900
112	1050	910
132	1520	1220
160	2800	2300
180	3250	2650
200	4340	3560
225	4950	4000
250	6050	4800
280	6300	5100
4 Poles 1500 RPM	Fr [N]°	Fr [N]max
63	430	390
71	520	440
80	800	700
90	950	780
100	1300	1050
112	1300	1050
132	1950	1600
160	3540	2825
180	4100	3400
200	5500	4550
225	6200	4900
250	7500	6000
280	8200	7500
6 Poles 1000 RPM	Fr [N]°	Fr [N]max
63	500	400
71	580	500
80	870	800
90	1090	900
100	1500	1250
112	1500	1250
132	2200	1800
160	4050	3190
180	4720	3830
200	6350	5150
225	7350	5650
250	8950	7200
280	9500	8500

Fa0: Permissible axial load **Fr:** Radial load **Fr0:** Permissible radial load at shaft spigot **Fr max:** Permissible radial load at shaft end point (permissible loads are calculated for L_{n10} 20000 h bearing lifetimes according to ISO 281.)

Axial loads



HORIZONTAL MOUNTING - Permissible Axial Loads Mounting Positions IM: B3, B5, B6, B7, B8, B14, B34, B35

Frame size	Push			Pull
	Fr=0	Fr=Fr ₀	Fr=FR _{max}	Fr=0
				
2 Poles 3000 RPM	Fa₀ [N]	Fa₀ [N]	Fa₀ [N]	Fa₀ [N]
63	90	90	90	220
71	110	110	110	250
80	190	190	190	395
90	210	210	210	400
100	270	270	270	580
112	270	270	270	580
132	380	380	370	800
160	2280	1060	1020	1670
180	2660	1250	1250	1970
200	3150	1500	1390	2600
225	3850	1850	1760	2750
250	4150	2180	2250	3350
280	4500	2500	2500	3350
4 Poles 1500 RPM	Fa₀ [N]	Fa₀ [N]	Fa₀ [N]	Fa₀ [N]
63	90	90	90	330
71	110	110	110	360
80	190	190	190	560
90	210	210	210	585
100	300	300	300	830
112	300	300	300	830
132	400	400	400	1200
160	2280	1400	1400	2350
180	3100	1570	1500	2800
200	4400	1770	1770	3810
225	4950	2150	2200	4300
250	6050	2400	2400	4500
280	7200	3000	3000	5500
6 Poles 1000 RPM	Fa₀ [N]	Fa₀ [N]	Fa₀ [N]	Fa₀ [N]
63	90	90	90	370
71	110	110	110	430
80	190	190	190	700
90	210	210	210	740
100	290	290	290	1020
112	290	290	290	1020
132	380	380	380	1470
160	3050	1540	1520	2900
180	3540	1780	1700	3410
200	4800	2200	2250	4400
225	5050	2580	2800	5200
250	6050	3100	3150	6500
280	7000	3700	3400	7150

Fa₀: Permissible axial load **Fr**: Radial load **Fr₀**: Permissible radial load at shaft spigot **Fr max**: Permissible radial load at shaft end point (permissible loads are calculated for L_{h,10} 20000 h bearing lifetimes according to ISO 281.)

Axial loads

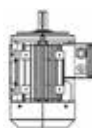

VERTICAL MOUNTING - Shaft Pointing Upwards Permissible Axial Loads Mounting Positions IM: V3, V6, V19, V35, V37

Frame size	Push			Pull
	Fr=0	Fr=Fr ₀	Fr=FR _{max}	Fr=0
2 Poles 3000 RPM	Fa ₀ [N]	Fa ₀ [N]	Fa ₀ [N]	Fa ₀ [N]
63	90	90	90	230
71	100	100	100	265
80	170	170	170	425
90	180	180	180	450
100	250	250	250	650
112	250	250	250	660
132	300	300	300	970
160	2080	1060	990	1950
180	2410	1190	1050	2350
200	2900	1265	1265	3000
225	3250	1310	1295	3575
250	3950	1460	1450	4350
280	4100	1500	1500	4700
4 Poles 1500 RPM	Fa ₀ [N]	Fa ₀ [N]	Fa ₀ [N]	Fa ₀ [N]
63	90	90	90	345
71	95	95	95	380
80	160	160	160	600
90	170	170	170	650
100	210	210	210	930
112	210	210	210	950
132	240	240	240	1430
160	2500	1250	1220	2160
180	2900	1400	1370	2570
200	3900	1360	1530	3500
225	4450	1570	1680	4000
250	5400	1870	1910	4300
280	6500	2250	2250	7100
6 Poles 1000 RPM	Fa ₀ [N]	Fa ₀ [N]	Fa ₀ [N]	Fa ₀ [N]
63	85	85	85	395
71	95	95	95	455
80	160	160	160	745
90	170	170	170	800
100	230	230	230	1120
112	210	210	210	1150
132	250	250	250	1690
160	2980	1490	1450	3300
180	3400	1670	1670	3800
200	4250	1850	1860	5100
225	4800	1980	2080	5800
250	5300	2200	2260	6200
280	6300	2200	2050	7500

Fa0: Permissible axial load **Fr:** Radial load **Fr0:** Permissible radial load at shaft spigot **Fr max:** Permissible radial load at shaft end point (permissible loads are calculated for L_{n10} 20000 h bearing lifetimes according to ISO 281.)

Axial loads

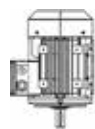

VERTICAL MOUNTING -Shaft Pointing Downwards Permissible Axial Loads Mounting Positions IM: V1, V5, V15, V17, V18

Frame size	Push			Pull
	Fr=0	Fr=Fr ₀	Fr=FR _{max}	Fr=0
2 Poles 3000 RPM	Fa₀ [N]	Fa₀ [N]	Fa₀ [N]	Fa₀ [N]
63	110	110	110	210
71	130	130	130	235
80	220	220	220	385
90	250	250	250	375
100	330	330	330	535
112	340	340	340	520
132	490	550	550	680
160	2600	1550	1500	1500
180	3070	1850	1750	1700
200	3550	2300	2300	2315
225	4250	2680	2670	2630
250	5200	3200	3280	3100
280	6000	3900	3900	2750
4 Poles 1500 RPM	Fa₀ [N]	Fa₀ [N]	Fa₀ [N]	Fa₀ [N]
63	120	110	120	300
71	130	130	130	340
80	220	220	220	540
90	260	260	260	545
100	380	370	370	760
112	410	400	400	740
132	580	570	570	1040
160	3500	1910	1840	2100
180	4000	2300	2170	2450
200	4250	2870	2850	2200
225	5000	3350	3380	3740
250	6200	4200	4000	4440
280	8900	4850	4850	4600
6 Poles 1000 RPM	Fa₀ [N]	Fa₀ [N]	Fa₀ [N]	Fa₀ [N]
63	110	110	110	360
71	130	130	130	415
80	220	220	220	675
90	250	250	250	700
100	360	360	360	960
112	390	390	390	930
132	560	560	560	1310
160	3100	2130	2120	2650
180	3600	2600	2490	3030
200	5000	3260	3300	4000
225	5550	3710	3810	4650
250	6200	4510	4550	5500
280	7500	5300	5200	5750

Fa₀: Permissible axial load **Fr**: Radial load **Fr₀**: Permissible radial load at shaft spigot **Fr max**: Permissible radial load at shaft end point (permissible loads are calculated for L_{h,10} 20000 h bearing lifetimes according to ISO 281.)



Additional information

*Please note that the
following items are by
request only*

Spare parts

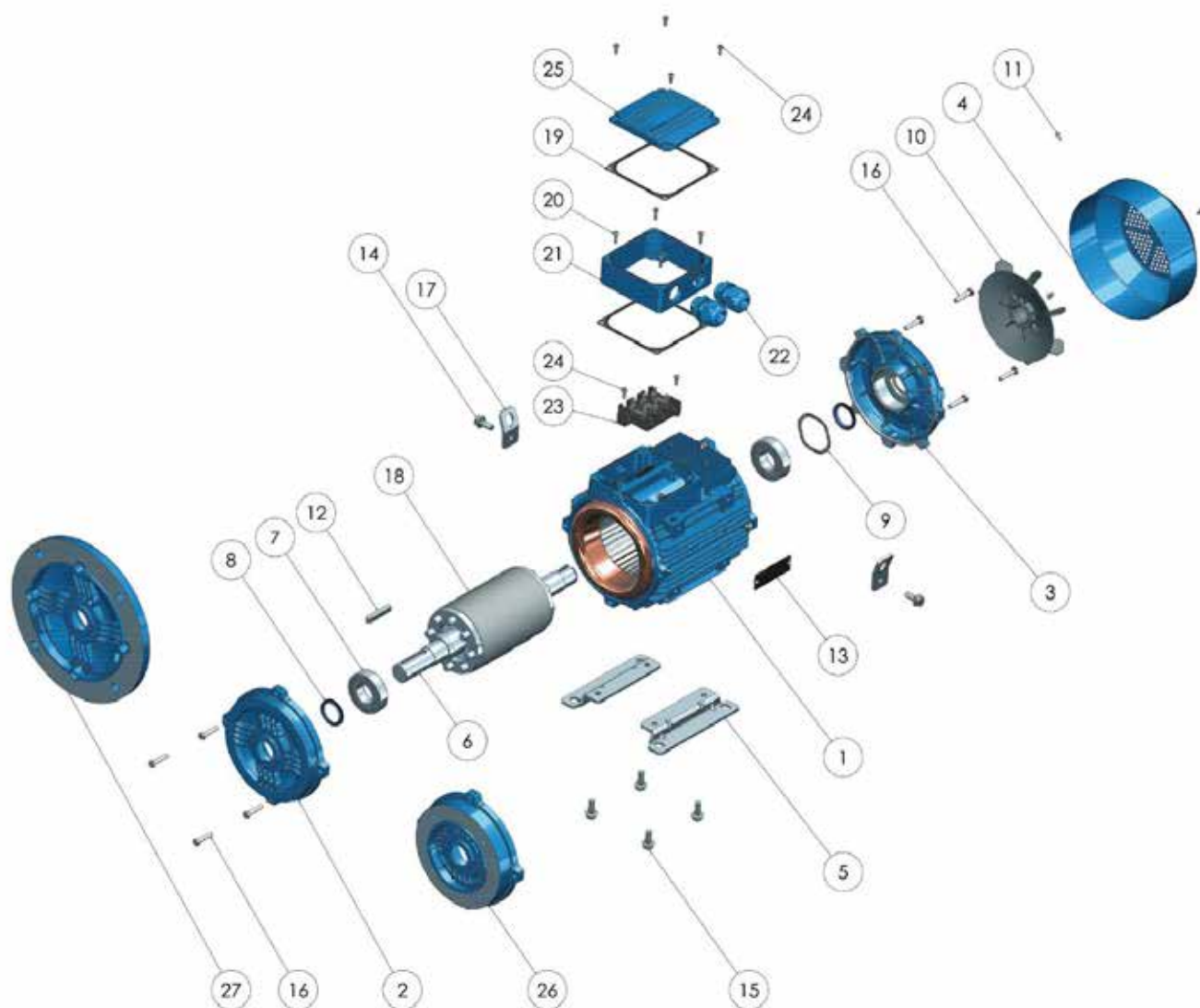

- | | | | |
|-----------|------------------|-----------|---------------------|
| 1 | Housing | 15 | Screw |
| 2 | End shield (DE) | 16 | Bolt |
| 3 | End shield (NDE) | 17 | Lifting lug |
| 4 | Fan cover | 18 | Squirrel cage rotor |
| 5 | Mounting foot | 19 | Terminal box gasket |
| 6 | Shaft | 20 | Screw |
| 7 | Bearing | 21 | Terminal box |
| 8 | Shaft sealing | 22 | Cable gland |
| 9 | Spring washer | 23 | Terminal |
| 10 | Fan | 24 | Screw |
| 11 | Screw | 25 | Terminal box cover |
| 12 | Key | 26 | Flange B14 |
| 13 | Nameplate | 27 | Flange B5 |
| 14 | Screw | | |

Anti-condensation heater and drain hole

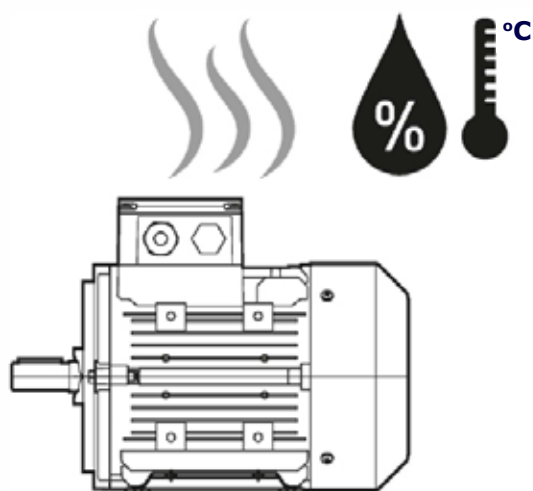

Water condensation inside the motor can occur in high humidity environments. To prevent this, heaters anti-condensation heaters are assembled to the motor windings to maintain a certain temperature.

In addition, drain holes are opened to prevent water from accumulating in the motor body in the event of water condensation inside the motor.

Non drive end shaft extension and canopy

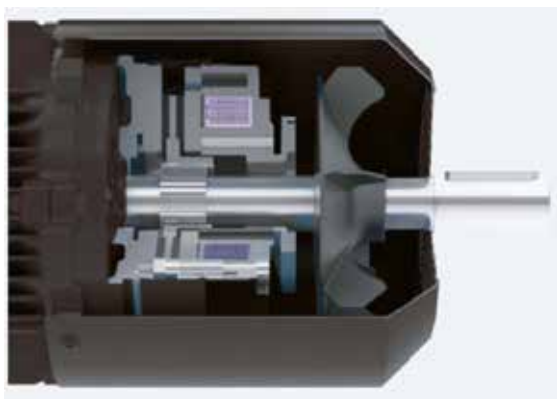

Non drive end shaft extension

Non drive end shaft is used when it is desired to transfer the motor power to a second load or to manually rotate it when the motor is not energized.



Canopy

It is used for operation in the outside environment where the motor fan is pointing upwards. This prevents the rainwater from entering the motor housing.

Brake, hand release, separately driven fan encoder and backstop

Electromagnetic brake

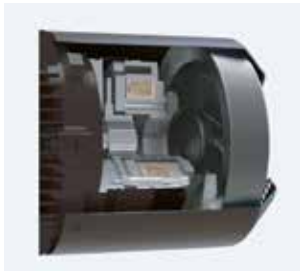

For each motor size we have the option of electromagnetic brake. Brakes with 24 Volt, 230 Volt and 400 Volt DC from 5Nm to 1600Nm are alternatively can be used as needed.

Brake with hand release

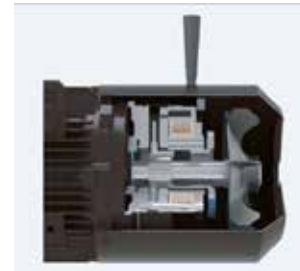

Hand release on the brake is used to release the system when the power is cut off or the power is not turned on.

Separately driven fan

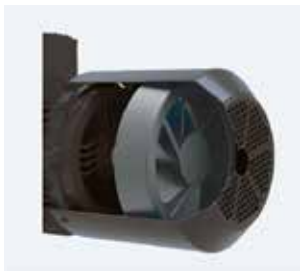

Separately driven fan is used particularly in applications where the motor is driven by variable speed drives to keep the air flow at a constant level.

Separately driven fan with encoder

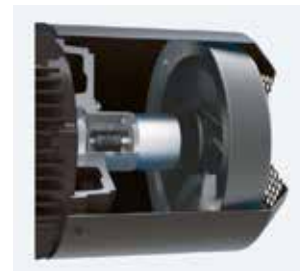

In applications where synchronous operation is desired, encoder application is used. The motor fan cannot be used since the encoder is mounted on the non drive end cover. For this reason, the motor is cooled by a separately driven fan.

Separately driven fan with brake and encoder



In applications where both brake and synchronous operation are desired, brake, encoder and separately driven fan options are all mounted to the non drive side of the motor.

Backstop



Backstop is used when the motor should rotate only in one direction and the motor should not rotate in the other direction. The backstop option in the fan cover is widely used.



ARUBIX
Company

In 1994 startte MCA met de verkoop van elektromotoren
en frequentieregelaars.

Inmiddels zijn we uitgegroeid tot een totaalleverancier en dé specialist
op het gebied van lineair-, aandrijf- en besturingstechniek.

Door onze lineaire, motion en robotics specialismen te combineren kunnen we elk
automatiseringsvraagstuk oplossen: op componentniveau of als totaaloplossing
inclusief software. Dit maakt ons uniek in Nederland!

Vanuit drie locaties door heel Nederland staan we
dagelijks voor u klaar met deskundig advies en persoonlijke service.

Daar zijn we trots op!

samen creëren en innoveren

DIVISIE: MOTION ROBOTICS

Markenweg 5
7051 HS Varsseveld

+31 (0)315 25 72 60

info@mcabv.nl

DIVISIE: LINEAR

Weteringstraat 11
7391 TX Twello

+31 (0)571 27 20 10

linear@mcabv.nl

DIVISIE: MOTION ROBOTICS

Sanderboutlaan 2b
6181 DN Elsloo

+31 (0)46 42 82 688

info@mcabv.nl

www.mcabv.nl